



PELLET THERMO FIREPLACE

VIVO 80 PELLET COMFORT AIR

COMFORT AIR SLIM MODEL
COMFORT AIR BASIC MODEL

Translation of the original instructions

MCZ

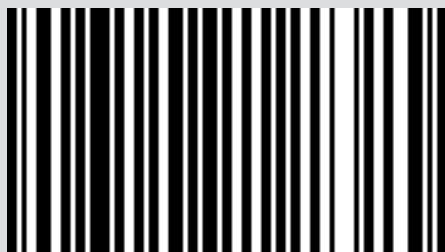

8901230200

TABLE OF CONTENTS

TABLE OF CONTENTS.....	II
INTRODUCTION	1
1 - WARNINGS AND WARRANTY CONDITIONS.....	2
2-INSTALLATION	8
3-DRAWINGS AND TECHNICAL FEATURES	17
4-UNPACKING.....	19
5-ASSEMBLY.....	20
6-FIRST START-UP	31
7-LOADING THE PELLETS	32
8-LCD REMOTE CONTROL.....	33
9-EMERGENCY PANEL	38
10-SAFETY DEVICES AND ALARMS	41
11-RECOMMENDATIONS FOR SAFE USE	45
12-MAINTENANCE AND CLEANING	46
13-PROBLEMS/CAUSES/SOLUTIONS	52
14-WIRING DIAGRAMS	55

INTRODUCTION

Dear Customer,

our products are designed and manufactured in compliance with European reference Standards for construction products (EN13240 wood-burning stoves, EN14785 pellet-burning appliances, EN13229 fireplaces/wood-burning inserts, EN 12815 wood-burning cookers), with high quality materials and extensive experience in the transformation processes. The products also meet the essential requirements of Directive 2006/95/EC (Low Voltage) and Directive 2004/108/EC (Electromagnetic Compatibility).

To get the best performance, we suggest you read the instructions in this manual carefully.

This installation and use manual forms an integral part of the product: ensure that the manual is always supplied with the device, even if the boiler changes owner. If the manual is lost, you can request another copy from the local technical service or download it directly from the company website.

All local regulations, including those regarding national and European regulations, must be respected when the device is installed.

In Italy, for the installation of devices with biomass lower than 35KW, refer to ministerial decree 37/08, and the qualified installation technician with the appropriate requisites must issue a certificate of compliance for the system installed. (By system one means Stove+Chimney+Air inlet).

REVISIONS TO THE PUBLICATION

The content of this manual is strictly technical and the property of MCZ Group Spa.





No part of this manual may be translated into other languages, adapted or reproduced, even in part, in other mechanical or electronic forms, photocopies, recordings or other, without the prior written authorisation from MCZ Group Spa.

The company reserves the right to make changes to the product at any time without prior notice. The proprietary company reserves its rights according to the law.

CARE OF THE MANUAL AND HOW TO CONSULT IT

- Take care of this manual and keep it in an easily accessible place.
- Should the manual be misplaced or ruined, request a copy from your retailer or directly from the authorised Technical Assistance Department. It can be downloaded from the company website.
- The “**text in bold**” must be read with particular care.
- The “*text in italics*” draws attention to other sections in this manual or clarifications.
- “NOTE” provides the reader with additional information.

SYMBOLS USED IN THE MANUAL

	ATTENTION: Read the relative message with care as failure to observe the information provided could result in serious damage to the product and put the persons who use it at risk.
	INFORMATION: failure to comply with these provisions will compromise the use of the product.
	OPERATING SEQUENCES: sequence of buttons to be pressed to access the menus or change settings.
	MANUAL carefully read this manual or the relative instructions.



SAFETY PRECAUTIONS

- **Installation, electrical connection, function test and maintenance must only be carried out by authorised and qualified personnel.**
- **Install the product in accordance with all local and national legislation and regulations in force in the region or state.**
- Only use the fuel recommended by the manufacturer. The product must not be used as an incinerator.
- It is strictly forbidden to use alcohol, petrol, liquid fuel for lanterns, diesel, bio-ethanol, fluids for lighting charcoal or similar liquids to light/rekindle the flame in these devices. Keep these flammable liquids well away from the appliance when in use.
- Do not put any fuel other than wood pellets in the hopper.
- The instructions provided in this manual must always be complied with to ensure the product and any electronic appliances connected to it are used correctly and accidents are prevented.
- **This appliance can be used by children aged 8 years and above and persons with reduced physical, sensory or mental capabilities or lack of experience and knowledge if they have been given supervision or instruction concerning use of the appliance in a safe way and understand the hazards involved. Children must not play with the appliance. Cleaning and user maintenance shall not be carried out by children without supervision.**
- The user, or whoever is operating the product, must read and fully understand the contents of this installation guide before performing any operation. Errors or incorrect settings can cause hazardous conditions and/or poor operation.
- Do not climb on or lean on the product.

1 - WARNINGS AND WARRANTY CONDITIONS

- Do not put linen on the product to dry. Any drying racks or similar objects must be kept at a safe distance from the product. **Fire hazard.**
- *All liability for improper use of the product is entirely borne by the user and relieves the Manufacturer from any civil and criminal liability.*
- Any type of tampering or unauthorised replacement with non-original spare parts could be hazardous for the operator's safety and relieves the company from any civil and criminal liability.
- Many of the surfaces of the product get very hot (door, handle, glass, smoke extraction pipes, etc.). **Avoid coming into contact with these parts without adequate protective clothing or suitable means, such as gloves with thermal protection** or "cold handle" operating systems.
- **It is forbidden to operate the product with the door open or the glass broken.**
- **The doors/covers on the appliance must remain closed when it is not used.**
- The product must be powered by an electrical system that is equipped with an effective earthing device.
- Switch the product off in the event of a fault or malfunction.
- Accumulated unburned pellets in the burner after each "failed start-up" must be removed before lighting again. Check that the burner is clean and positioned properly before lighting again.
- Do not wash the product with water. The water could get inside the unit and damage the electrical insulation and cause electric shocks.
- Do not stand for a long time in front of the product in operation. Do not overheat the room you are in and where the product is installed. This could cause injuries and health problems.
- Install the product in a location that does not present a fire hazard and is equipped with power and air supplies and smoke extractors.
- In the event of fire in the chimney, turn off the device, disconnect it from the mains electricity and do not open the hatch. Then contact the competent authorities.
- The product and the cladding must be stored in a dry place and must not be

1 - WARNINGS AND WARRANTY CONDITIONS

exposed to weathering.

- It is recommended not to remove the feet that support the product in order to guarantee adequate insulation, especially if the flooring is made of flammable materials.
- In the event of a malfunction with the ignition system, do not force it to light by using flammable materials.
- Special maintenance must only be performed by authorised and qualified personnel.
- Assess the static conditions of the surface on which the weight of the product will rest and provide suitable insulation if it is made of flammable material (e.g. wood, fitted carpet or plastic).
- Live electrical parts: only power the product once it has been fully assembled.
- Disconnect the product from the 230V power supply before performing any maintenance operation.
- Improper use or poor maintenance of the product can cause hazardous situations to arise.
- **It is forbidden to manually load the fuel into the brazier. Failure to follow this warning can lead to hazardous situations.**
- **Before the product is restarted, always remove any unburned pellets building up in the brazier due to failed ignition, the emptying of the tank or any situation that may cause this condition.**

1 - WARNINGS AND WARRANTY CONDITIONS

• INFORMATION:

Please contact the retailer or qualified personnel authorised by the company to resolve a problem.

- You must only use the fuel specified by the manufacturer.
- When the product is switched on for the first time it is normal for it to emit smoke due to the paint heating for the first time. Therefore make sure the room in which it is installed is well ventilated.
- Check and clean the smoke extraction pipes regularly (connection to the chimney).
- The product is not a cooking appliance.
- Always keep the cover of the fuel hopper closed.
- Store this installation and use manual with care as it must accompany the product for the duration of its useful life. If the product is sold or transferred to another user, ensure the manual is also handed over.

INTENDED USE

The product only works with wood pellets and must be installed indoors.

WARRANTY CONDITIONS

The company guarantees the product, **with the exception of elements subject to normal wear** (listed on the following page), for a period of **2 (two) years** from the date of purchase attested by:

- a document to serve as proof of purchase (invoice and/or receipt) that shows the name of the vendor and the date on which the purchase was made;
- forwarding of the completed certificate of guarantee within 8 days of purchase.

Furthermore, in order for the guarantee to be valid, the device must be installed and calibrated by qualified personnel, and where necessary, the user must be issued with a declaration of conformity and correct functioning of the product.

We recommend performing a functional test of the product before completion with the relative finishes, if applicable (claddings, painting of walls, etc.).

Any installation that fails to comply with the regulations in force will invalidate the product guarantee, as will improper use or failure to carry out the maintenance prescribed by the manufacturer.

The guarantee is valid on the condition that the instructions and warnings contained in the use and maintenance manual are observed, and therefore the product is used correctly.

The replacement of the entire system or the repair of one of its components does not extend the guarantee period, and the original expiry date remains unchanged.

The guarantee covers the replacement or free repair **of parts recognised as being faulty at source due to manufacturing defects**. To benefit from the guarantee, in the event of a fault, the customer must have the guarantee certificate and present it with the proof of purchase document to the Technical Assistance Office.

1 - WARNINGS AND WARRANTY CONDITIONS

EXCLUSIONS

The guarantee does not cover malfunctions and/or damage to the appliance that arise due to the following causes:

- Damage caused during transportation or relocation
- all parts that develop faults due to negligence or improper use, incorrect maintenance, installation that does not comply with the manufacturer's instructions (always refer to the installation and use manual provided with the appliance)
- incorrect dimensioning with regards to the use or faults in the installation or failure to adopt the necessary devices to guarantee proper execution
- improper overheating of the equipment, use of fuels not conforming to the types and quantities indicated in the instructions provided
- further damage caused by incorrect user interventions in an attempt to fix the initial fault
- worsening of the damage due to the continued use of the equipment by the user, once the defect has been noticed
- in the presence of a boiler, any corrosions, incrustations or breaks caused by water flow, condensation, hardness or acidity of the water, improperly performed descaling treatments, lack of water, mud or limescale deposits
- inefficiency of chimneys, flues or parts of the plant affecting the equipment
- damage caused by tampering with the appliance, atmospheric agents, natural disasters, vandalism, electrical discharges, fires, faults in the electric and/or hydraulic system.
- Failure to have the annual stove maintenance performed by an authorised technician or qualified personnel will result in the loss of the warranty.

Also excluded from this guarantee are:

- parts subject to normal wear such as gaskets, glass, claddings and cast iron grids, painted, chrome-plated or gilded parts, handles and electric cables, bulbs, indicator lights, knobs, all parts which can be removed from the hearth.
- Variations in colour of the painted or ceramic/serpentine parts and craquelure ceramics as they are natural characteristics of the material and product use.
- masonry work
- plant parts (if present) not supplied by the manufacturer

Any technical interventions on the product to eliminate the above-said defects and consequent damages must be agreed upon with the Technical Assistance Centre, who reserves the right to accept the relative appointment or not. However, said interventions will not be carried out under warranty but as technical assistance to be granted at part of any eventual and specific agreed conditions and in accordance with the fee in force for the work to be carried out.

The user will also be charged for any costs incurred to remedy the incorrect technical interventions, tampering or damage to the appliance, not attributable to original faults.

Save for the legal or regulatory limits, the guarantee does not cover the containment of atmospheric and acoustic pollution.

The company declines all liability for any damage which may be caused, directly or indirectly, to persons, animals or objects as a consequence of non compliance with any prescription specified in the manual, especially warnings regarding installation, use and maintenance of the appliance.

1 - WARNINGS AND WARRANTY CONDITIONS

SPARE PARTS

In the event of a malfunction, consult the retailer who will forward the call to the Technical Assistance Service.

Use only original spare parts. The retailer or service centre can provide all necessary information regarding spare parts. We do not recommend waiting for the parts to be worn before having them replaced. It is important to perform regular maintenance.



The company declines all liability if the product and any other accessory is used improperly or modified without authorisation.

All parts must be replaced with original spare parts.

WARNINGS FOR THE CORRECT DISPOSAL OF THE PRODUCT.

The owner is the sole party responsible for demolishing and disposing of the product. This must be performed in compliance with laws related to safety and environmental protection in force in his/her country.

At the end of its working life, the product must not be disposed of as urban waste.

It must be taken to a special differentiated waste collection centre set up by the local authorities or to a retailer that provides this service. Separating and recycling prevents potential negative effects on the environment and health (often caused by inappropriately disposing of product parts). It also allows materials to be recovered in order to obtain significant savings in energy and resources.

2-INSTALLATION



The instructions in this chapter refer explicitly to the Italian installation regulation UNI 10683. In any case, always observe the domestic regulations in force.

PELLETS

Wood pellets are manufactured by hot-extruding compressed sawdust which is produced during the working of natural dried wood. The compactness of the material is guaranteed by the lignin contained in the wood itself and allows pellets to be produced without glue or binders.

The market offers different types of pellets with characteristics that vary according to the wood mixtures used. The most common diameter on the market is 6 mm (although 8 mm diameter is available too) with a length, on average, of between 3 and 40 mm. A good quality pellet has a density of between 600 and 750 or more kg/metres cubed and a water content that accounts for 5 to 8% of its weight. Pellets have technical advantages besides being an ecological fuel, as the wood residue is used completely, thereby achieving cleaner combustion than that of fossil fuels.

Good-quality wood has a calorific value of 4.4 kW/kg (15% moisture, after about 18 months of seasoning), whereas that of pellets is 4.9 kW/kg. To ensure good combustion, the pellets must be stored in a dry place and protected from dirt. Pellets are usually supplied in 15 kg bags, therefore, storing them is very convenient.



15 Kg BAGS OF FUEL

Good quality pellets guarantee good combustion, thereby decreasing harmful emissions into the atmosphere.



The poorer the quality of the fuel, the more often the internal parts of the brazier and combustion chamber must be cleaned.

The main quality certifications for pellets currently available on the European market guarantee that the fuel complies with class A1/A2 according to ISO 17225-2 (ex EN 14961). These certifications include, for example, **ENPlus**, **DINplus**, **Ö-Norm M7135**, and in particular, guarantee the following characteristics:

- calorific value: 4.6 ÷ 5.3 kWh/kg.
- Moisture content: ≤ 10% of the weight.
- Percentage of ash: max 1.2% of the weight (A1 less than 0.7%).
- Diameter: 6±1/8±1 mm.
- Length: 3÷40 mm.
- Content: 100% untreated wood without the addition of binding substances (max 5% bark).
- Packaging: in sacks made from ecologically compatible or biologically decomposing material.



The company strongly recommends using certified fuel for its products (ENplus, DINplus, Ö-Norm M7135). Poor quality pellets or others that do not comply with the characteristics specified previously may compromise the operation of your product and can therefore render the guarantee and product liability invalid.

2-INSTALLATION

FOREWORD

The installation position must be chosen according to the room, to the smoke extraction system, to the chimney flue. Check with local authorities whether there are any restrictive regulations in force regarding the combustion air inlet, the smoke outlet system, the flue or the chimney cap. The manufacturer declines all responsibility in the event of installations that do not comply with the laws in force, incorrect room air exchange, electrical connection non-compliant with the standards and inappropriate use of the appliance. The installation must be carried out by a qualified technician, who must issue a declaration of conformity of the system to the purchaser and will assume full responsibility for final installation and consequent good operation of the product.

In particular one must ensure that:

- there is a suitable combustion air inlet and smoke outlet in compliance with the type of product installed
- other stoves or devices installed do not cause depression in the room where the product is installed (for sealed appliances only, a maximum of 15 Pa of depression in the room is allowed)
- when the product is switched on there is no reflux of smoke in the room
- fumes extraction takes place in total safety (sizing, smoke seal, distances from flammable materials..).

We especially recommend to check the data tags of the flue for the safety distances that must be observed in presence of combustible materials and the type of insulating material to be used. These indications must be followed strictly to prevent serious harm to people and the integrity of the home. The installation of the appliance must ensure easy access to clean the appliance itself, the smoke outlet pipes and the flue. **It is forbidden to install the stove in rooms with a fire hazard. Installation in studio flats, bedrooms and bathrooms is only allowed with sealed or closed appliances equipped with suitable combustion air ducting directly outside. Always maintain adequate distance and protection in order to prevent the product from coming into contact with water.**

In the event there are several appliances installed, the external air inlet must be sized accordingly.

MINIMUM DISTANCES

It is recommended to install the stove detached from any walls and/or furniture, with a minimum clearance to allow effective aeration of the appliance and a good distribution of heat in the room. Comply with the distances from flammable or heat-sensitive objects (sofas, furniture, wood panelling, etc.) as specified below. The frontal distance from flammable materials must be at least as specified in the product's technical data table.

If particularly delicate objects are present, such as furniture, curtains or sofas, increase the stove clearance accordingly.



If the floor is made of wood, it is recommended to fit a floor protection sheet in compliance with the Standards in force in the country of installation.

VIVO 80 PELLET	Non-flammable walls	Flammable walls
Comfort Air Version	A = 20 mm B = 20 mm	A = 50 mm B = 50 mm

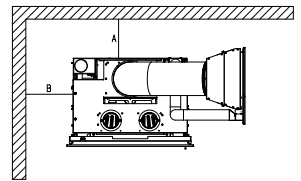

If the floor is made of combustible material, it is recommended to use protection made of non-combustible material (steel, glass...) that also protects the front from falling combusted material during cleaning operations.

The appliance must be installed on a floor with adequate load capacity.

If the existing construction does not meet this requirement, one must take appropriate measures (for example a load distribution plate).

2-INSTALLATION

FOREWORD

This chapter on the Smoke Flue has been produced in reference to the prescriptions of European regulations (EN13384 - EN1443 - EN1856 - EN1457).

The chapter provides indications for installing an efficient and correct smoke flue but is under no circumstances to substitute the regulations in force, which the qualified technician must be in possession of. Check with local authorities whether there are any restrictive regulations in force regarding the intake of air for combustion, the smoke extraction system, the flue or the chimney.

The company declines all liability relating to the poor functioning of the boiler if this is due to the use of an insufficiently sized flue in violation of regulations in force.

SMOKE FLUE

The flue or chimney is of great importance for the proper operation of a solid fuel-burning heating appliance with natural draught, as modern heating appliances have high efficiency with cooler flue gasses and consequently less draught, it is therefore essential that the flue is built up to standard and always kept in perfect working order. A flue that serves a pellet/wood fuelled appliance must be at least category T400 (or greater if the appliance requires, and resistant to soot fires. Smoke must be extracted through a single flue made of insulated steel (A) or an existing flue that complies with the intended use (B).

A simple air shaft in cement must be suitably lined. In both solutions there must be an inspection cap (AT) and/or inspection hatch (AP) - FIG. 1.

It is prohibited to connect more than one wood/pellet or any other type of appliance (vent cowling...) to the same flue.

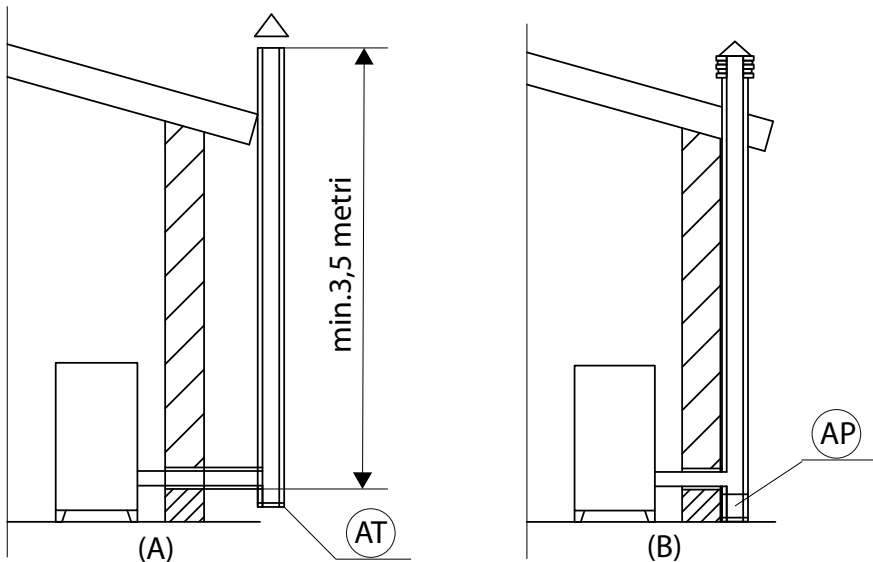

FIGURE 1 - SMOKE FLUE

2-INSTALLATION

TECHNICAL CHARACTERISTICS

Have the efficiency of the flue checked by an authorised technician.

The flue must be sealed against flue gasses, in a vertical direction without narrowing, be made with materials impermeable to smoke, condensation, thermally insulated and suitable to resist normal mechanical stress over time (we recommend fireplaces made of A/316 or refractory material with insulated round section double chamber). Be suitably insulated externally to avoid condensation and reduce smoke cooling. It should be separated from combustible or flammable materials with an air gap or insulating materials: check the distance specified by the manufacturer of the fireplace according to EN1443. The chimney opening must be in the same room as the appliance, or at most in the adjoining room, and have a soot and condensation collection chamber beneath the opening, and be accessible via a watertight metal hatch.

FLAT ROOF

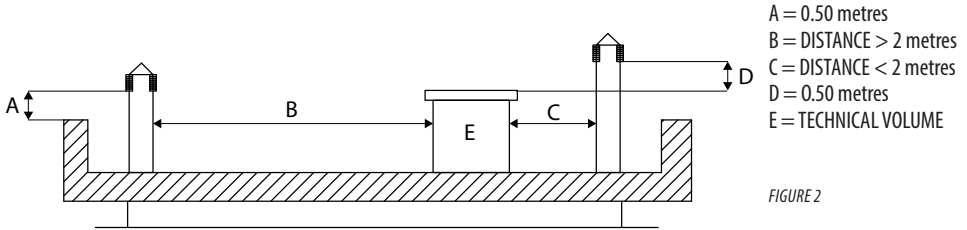

FIGURE 2

ROOF AT 15°

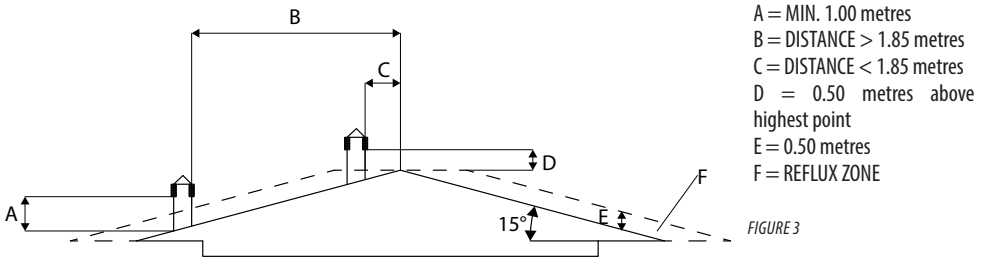

FIGURE 3

ROOF AT 30°

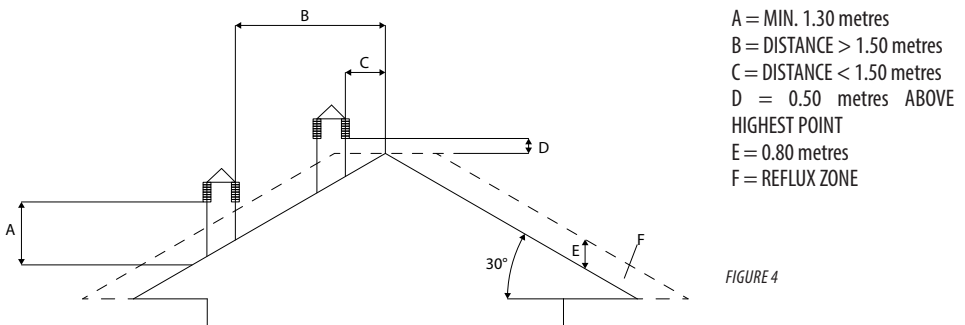

FIGURE 4

2-INSTALLATION

ROOF AT 60°

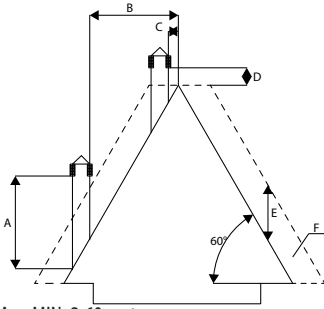

FIGURE 5

- A = MIN. 2.60 metres
- B = DISTANCE > 1.20 metres
- C = DISTANCE < 1.20 metres
- D = 0.50 metres ABOVE HIGHEST POINT
- E = 2.10 metres
- F = REFLUX ZONE

ROOF AT 45°

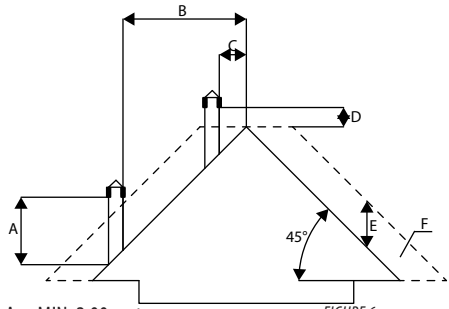

FIGURE 6

- A = MIN. 2.00 metres
- B = DISTANCE > 1.30 metres
- C = DISTANCE < 1.30 metres
- D = 0.50 metres ABOVE HIGHEST POINT
- E = 1.50 metres
- F = REFLUX ZONE

DIMENSIONING

The drop in pressure (draft) of a flue depends on its height. Check the drop in pressure with the values indicated in the technical characteristics. The minimum height of the chimney is 3.5 metres.

The interior cross-section of the flue can be circular (best variation), square or rectangular (the ratio between the interior sides must be ≤ 1.5) with the sides joined with a minimum radius of 20 mm. The dimension of the cross-section must be **minimum $\varnothing 100\text{mm}$** .

The cross sections/lengths of chimneys must be correctly sized in accordance with the general method of calculation of UNI EN13384-1 or other proven efficiency methods.

Below is a list of some flues available on the market:

Steel chimney AISI 316 with double chamber insulated with ceramic fibre or equivalent resistant up to 400°C.

Refractory chimney with double insulated chamber and external lightweight concrete cladding with cellular material such as clay.

Traditional square-section clay chimney with insulating empty inserts.

Avoid products with an internal rectangular section where the larger side is 1.5 times the smaller side (e.g. 20x40 or 15x30).

EXCELLENT

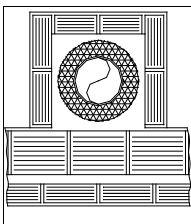

GOOD

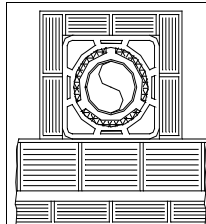

POOR

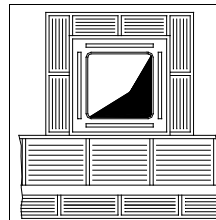

VERY POOR

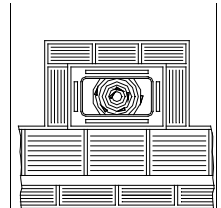

2-INSTALLATION

MAINTENANCE

The flue must be kept clean, since the deposit of soot or unburned oils reduces the cross-section reducing the draft and thus compromising the efficient functioning of the heater and, if large build-ups accumulate, can catch fire. The flue and chimney must be cleaned and checked by a qualified chimney sweep at least once a year. Once the maintenance has been performed, request a written declaration that the device is safe.

Failure to clean the system jeopardises the safety.

CHIMNEY

The chimney is a crucial element for the heating appliance to work properly: we recommend a wind proof chimney (A), see Figure 7.

The area of the opening for smoke extraction must be at least double the cross-section of the smoke duct/flue system, and arranged so that smoke extraction is ensured even in strong wind. The chimney must prevent rain, snow or animals from entering the chimney. The height of outflow into the atmosphere must be beyond the reflux zone created by the shape of the roof or any obstacles near the outlet (see Figures 2-3-4-5-6).

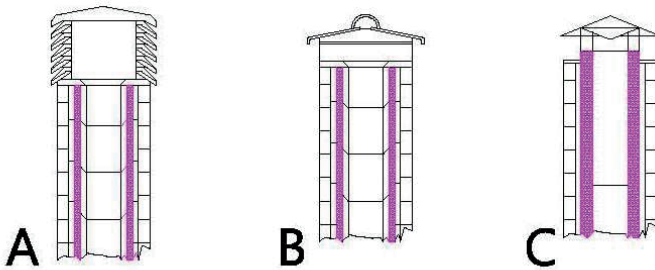
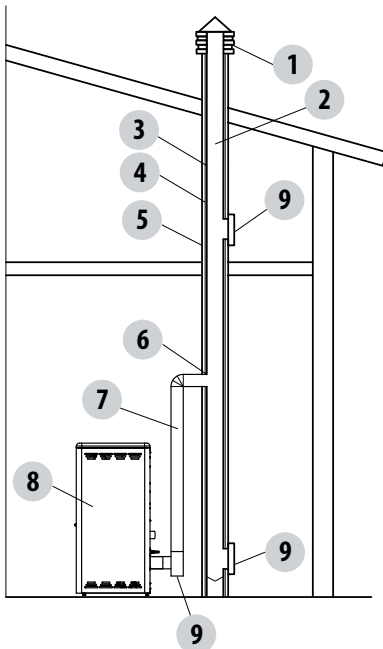

FIGURE 7

CHIMNEY COMPONENTS



KEY:

- (1) CHIMNEY
- (2) REFLEX CHANNEL
- (3) SMOKE DUCT
- (4) THERMAL INSULATION
- (5) OUTSIDE WALL
- (6) CHIMNEY CONNECTION
- (7) SMOKE CHANNEL
- (8) HEAT GENERATOR
- (9) INSPECTION ACCESS PANEL

FIGURE 8

2-INSTALLATION

EXTERNAL AIR INLET

It is mandatory to provide an adequate external air intake that supplies the combustion air required for the product to work properly. The flow of air between the outside and the installation room may be direct, through an inlet in an external wall of the room; or indirect, via air intake from adjoining rooms and connecting permanently with the installation room (see Figure 9 b). Adjoining areas may not include sleeping areas, garages or general areas with a fire hazard. During installation one must check the minimum clearances required for air intake from outside. Take into account the presence of doors and windows that could interfere with the proper flow of air to the stove (see diagram below).

The air intake must have a minimum total net area of 80 cm²: the surface must be increased accordingly if within the room there are other active generators (for example: electric fan for stale air extraction, kitchen hood, other stoves, etc...), which could cause cause depression in the room. One must verify that, with all the equipment on, the pressure drop between the room and the outside does not exceed a value of 4 Pa. If necessary increase the intake section of the air inlet, which must be made at floor level and always protected with a bird-proof outer protection grid and in such a way that it cannot be obstructed by any object.

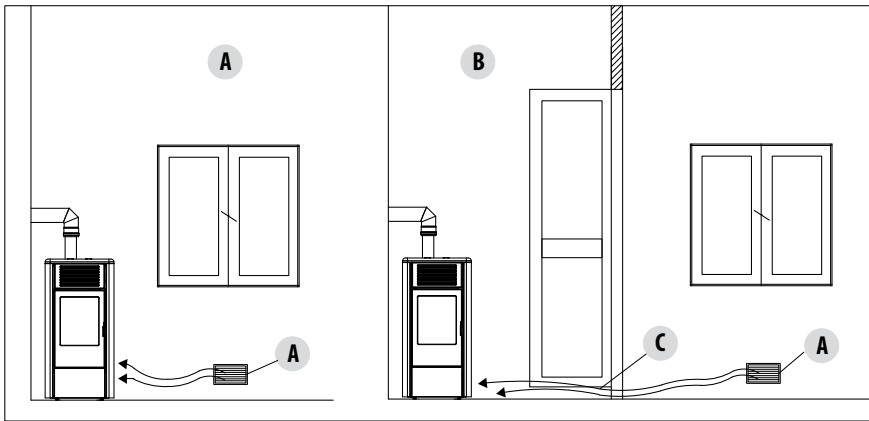
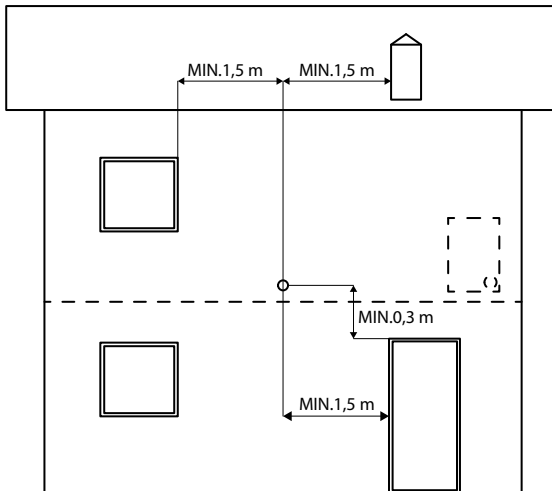

FIGURE 9 A - DIRECTLY FROM OUTSIDE

FIGURE 9 B - INDIRECTLY FROM THE ADJACENT ROOM



A=AIR INLET
B=ROOM TO BE VENTILATED
C=INCREASE OF THE GAP UNDER THE DOOR

It is possible to connect the air required for combustion directly to the outside air inlet, with a pipe of at least Ø50mm, with maximum length of 3linear metres; each pipe bend shall be considered equivalent to a linear metre. To attach the pipe see the back of the stove.

For stoves installed in studio flats, bedrooms and bathrooms (where allowed), it is mandatory to connect the combustion air outside. In particular for sealed stoves the connection must be sealed in order not to compromise the overall sealed characteristic of the system.

FIGURE 10

2-INSTALLATION

DISTANCE (metres)	The air inlet must be at a distance of:	
1.5 m	UNDER	Windows, doors, smoke outlets, cavities,
1.5 m	HORIZONTALLY	Windows, doors, smoke outlets, cavities,
0.3 m	ABOVE	Windows, doors, smoke outlets, cavities,
1.5 m	AWAY	from smoke outlet

CONNECTION TO FLUE

The connection between the flue and the appliance must be via a smoke duct that conforms with EN 1856-2. The connecting section must extend no more than 4 m horizontally, with a maximum incline of 3% and containing a maximum of 3 90° bends (accessible for inspection - do not count the T joint at the appliance outlet).

The diameter of the smoke duct must be equal to or greater than that of the appliance outlet (Ø 80 mm).

TYPE OF DEVICE	SMOKE DUCT
Minimum vertical length	1.5 metres
Maximum length (with 1 accessible 90° bend)	6.5 metres
Maximum length (with 3 accessible 90° bends)	4.5 metres
Maximum number of accessible 90° bends	3
Horizontal sections (minimum incline 3%)	4 metres

Use a smoke duct according to the regulations in force in the country of installation and verify that it is compatible with the product and installation characteristics. The temperature class of the smoke duct must exceed operating temperatures of the appliance.

It is prohibited to connect more than one appliance to the same smoke duct, or the discharge from overhead cawling. It is prohibited to extract the products of combustion directly through the wall, whether into indoor spaces or outdoors.

Should there be flammable or heat-sensitive structures, the smoke duct must respect the safety distances specified in the data plate.

2-INSTALLATION

EXAMPLES OF CORRECT INSTALLATION

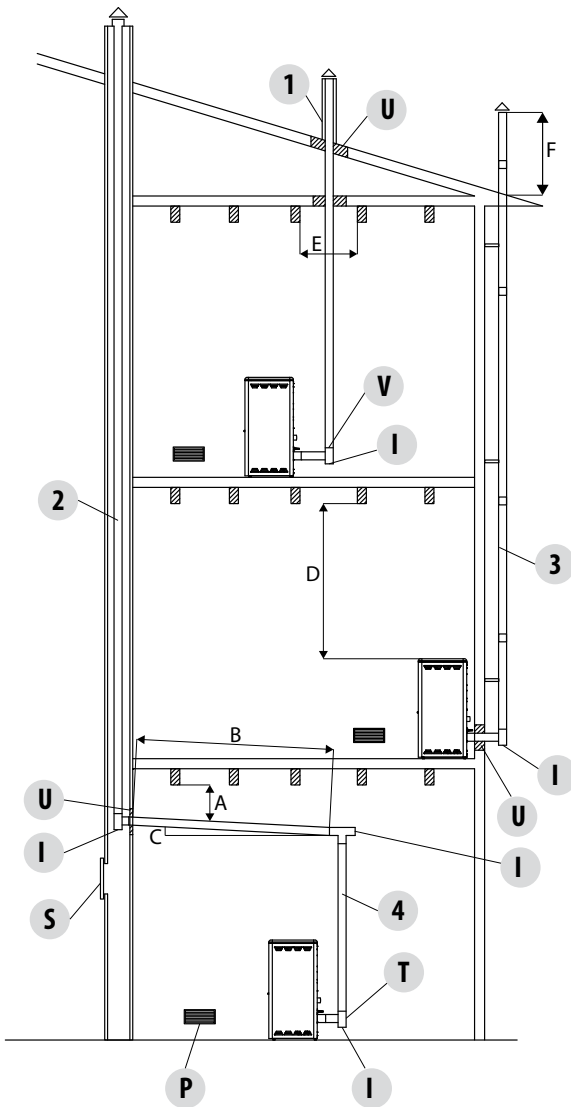

1. Installation of $\varnothing 150\text{mm}$ flue with hole for the passage of the tube increased by:
 minimum 100 mm around the tube if next to non flammable parts such as cement, brick, etc.; or
 minimum 300 mm around the tube (or as prescribed by data tags) if next to flammable parts such as wood etc.
 In both cases, install suitable insulation between the flue and the ceiling.

Always check and respect the data tags on the flue, in particular the minimum safety distances from combustible materials.

The previous rules also apply for holes made in walls.

2. Old flue, minimum pipe $\varnothing 100\text{mm}$ with the inclusion of an external access door for chimney cleaning.

3. External flue made of insulated stainless steel pipes, i.e. with double walls minimum $\varnothing 100\text{mm}$: all securely mounted on the wall. With wind-proof chimney. See fig. 7 type A.

4. Ducting system using T joints that allow easy access for cleaning without having to remove the tubes

FIGURE 11

U = INSULATING
 V = ANY REDUCTION FROM 100 TO 80 MM
 I = INSPECTION CAP
 S = INSPECTION ACCESS PANEL
 P = AIR INLET
 T = T JOINT WITH INSPECTION CAP

A = MINIMUM 40 MM
 B = MAXIMUM 4 M
 C = MINIMUM 3°
 D = MINIMUM 400 MM
 E = HOLE DIAMETER
 F = SEE FIG. 2-3-4-5-6

3-DRAWINGS AND TECHNICAL FEATURES

DRAWINGS AND CHARACTERISTICS DIMENSIONS: VIVO 80 PELLET COMFORT AIR

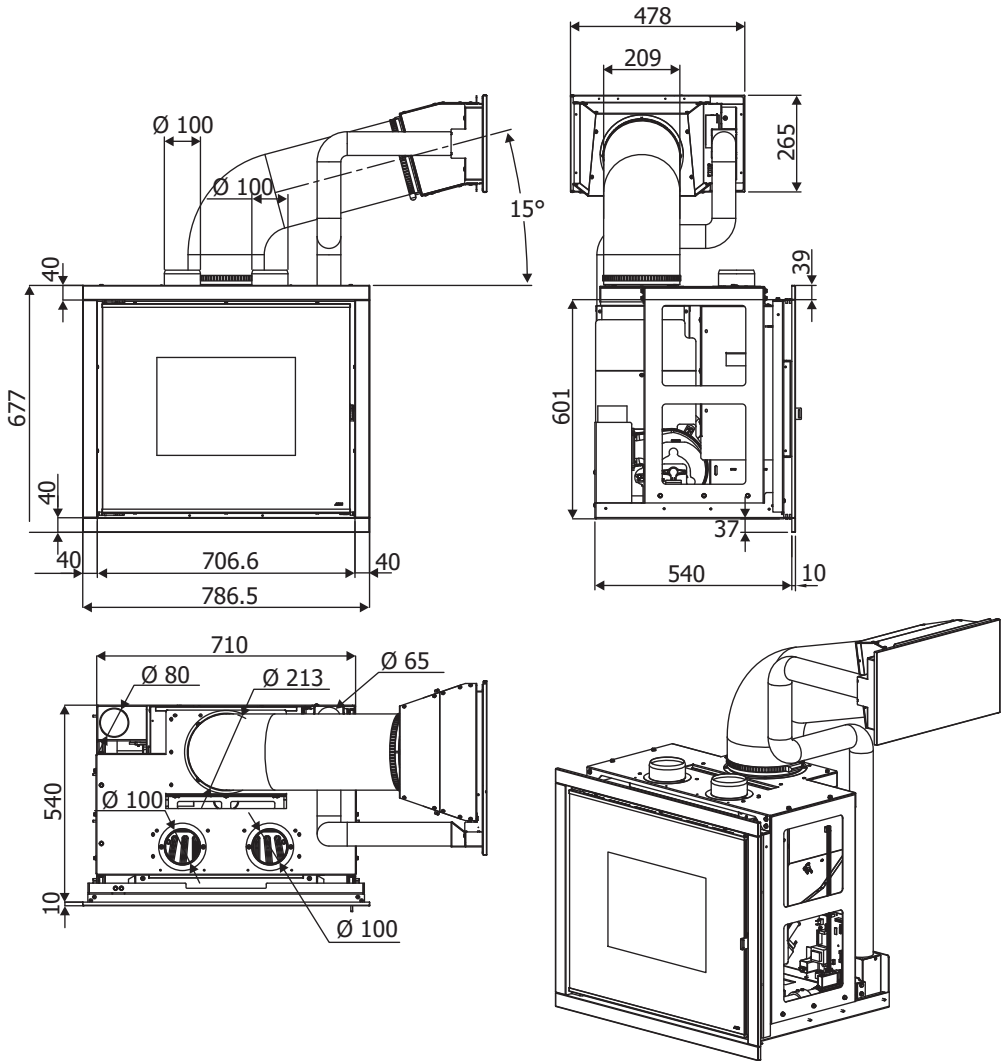

3-DRAWINGS AND TECHNICAL FEATURES

TECHNICAL CHARACTERISTICS	VIVO 80 PELLET COMFORT AIR (SLIM-BASIC)
Nominal output power	10,5 kW (9030 kcal/h)
Minimum output power	2,7 kW (2322 kcal/h)
Efficiency at Max	92,2%
Efficiency at Min	95,8%
Temperature of exhaust smoke at Max	170 °C
Temperature of exhaust smoke at Min	70 °C
Particulate/OGC/Nox (13%O ₂)	19 mg/Nm ³ - 2 mg/Nm ³ - 133 mg/Nm ³
CO at 13% O ₂ at Min and at Max	0,03 – 0,01%
CO ₂ at Min and at Max	6,4% - 8,1%
Recommended draught at Max ***power	0,10 mbar - 10 Pa***
Minimum draft allowed at minimum power	0,02 mbar - 2 Pa
Mass of smoke	8,9 g/sec
Hopper capacity	20+15 litres
Type of pellet fuel	Pellet diameter 6-8 mm and size 3÷40 mm
Pellet hourly consumption	Min ~ 0,6 kg/h* - Max ~ 2,2 kg/h*
Autonomy	At min ~ 39 h* - At max ~ 11 h*
Heatable volume m ³	226/40 – 258/35 – 301/30 **
Combustion air inlet	External diameter 50 mm
Smoke outlet	External diameter 80 mm
Air inlet	80 cm ²
Nominal electrical power (EN 60335-1)	100 W (Max 420 W)
Supply voltage and frequency	230 Volt / 50 Hz
Net weight	170 kg
Weight with packaging	190 kg
Distance from combustible material (back/side/under)	50/50/0 mm
Distance from combustible material (ceiling/front)	800/1000 mm

* Data that may vary depending on the type of pellets used

** Volume that can be heated, according to the power requirement per m³ (respectively 40-35-30 Kcal/h per m³)

***Value recommended by the manufacturer (non-binding) for optimal product operation

Tested according to EN 14785 in accordance with European regulation for Construction Products (EU 305/2011)

4-UNPACKING

PREPARATION AND UNPACKING

The product is supplied in a single package. The pipe, feeding door and ventilation grille are packaged inside. A box is placed on top of the package with the Comfort Air Slim or Basic Kit inside.

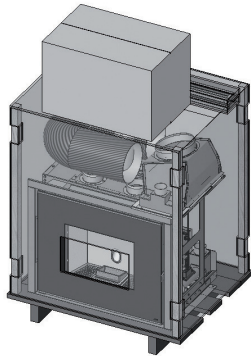

PACKAGING: VIVO 80 PELLET
COMFORT AIR

Open the package, remove the product from the pallet and set it in the pre-selected place, making sure this complies with the requirements. The two brackets must be removed in order to remove the product from pallet, by loosening the two flanged nuts and the two screws.

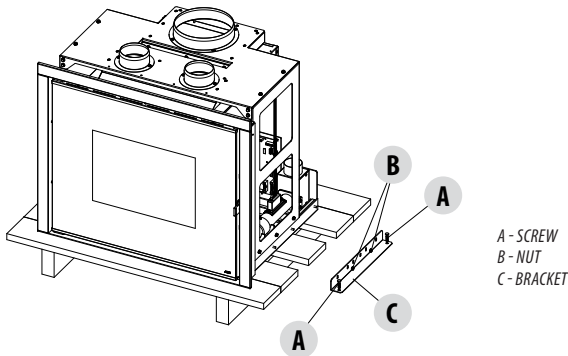

The appliance must always remain in a vertical position and handled solely with a cart. Pay particular attention to the door and its glass, protecting them from mechanical knocks that would compromise their integrity.

In any case, the product must always be handled with care. If possible, unpack the product near the place of installation. The packaging materials are neither toxic nor harmful, and therefore no particular disposal measures are required. Therefore, the end user is responsible for product storage, disposal or possible recycling in compliance with the relative applicable laws.

If the product must be connected to an exhaust pipe that goes through the rear wall (to enter the flue), make sure not to force it in.

5-ASSEMBLY

COMBUSTION AIR

During operation a certain amount of air is drawn from the room in which the product is installed and this air must be supplemented through an air inlet.

The combustion air in this product is autonomously drawn directly from the grille on the pellet loading door. The 65 mm diameter pipe supplied must be connected to the product and the door as shown in the figure.

The user can decide to draw the combustion air from outside, in which case, the pipe must be connected to the product and an external air intake.

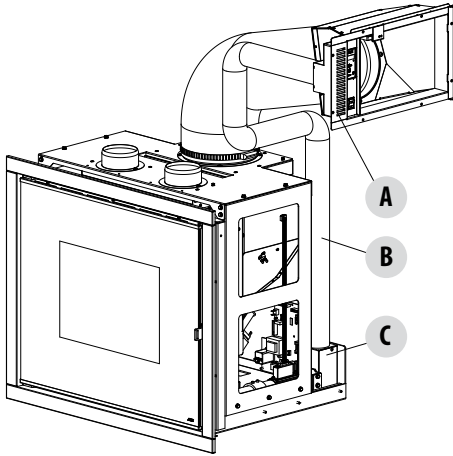

A-AIR INLET FROM THE PELLETT LOADING
DOOR
B-PIPE
C-PIPE CONNECTION TO THE PRODUCT

HOT AIR OUTLET DUCTING

The product can distribute the hot air by **Forced Convection** by means of a forced ventilation kit (supplied).

The product comes with two types of kits:

- Comfort Air Slim.
- Comfort Air Basic.

The main characteristics of the two kits are:

- Kit Comfort Air Slim - 12 multi diffuser, 60 mm diameter ducting and a motor between the thermo fireplace and the diffuser.
- Kit Comfort Air Basic - 20 multi diffuser, 100 mm diameter ducting and a motor behind the fan.

Other optional types of diffusers can be applied depending on the kit chosen.

Refer to the relative manual inside the kit for the installation instructions.

An air intake must be installed in the place of installation in order to guarantee the air for combustion.

5-ASSEMBLY

POSITIONING

Evaluate the optimal condition of installation before placing the product.

The product can be installed in an existing traditional firebox or as a new system.

Furthermore, an iron support can be purchased separately in order to raise the product to the recommended height, 500 mm, (see the relative price list of accessories - optional) or build a base on site.

INSTALLING IN AN EXISTING FIREBOX

Evaluate the following elements:

The product support surface must have the following characteristics:

- bear the weight of the product and any accessories
- its texture must allow anchors to be set with dowels for safety purposes
- be perfectly level
- the back panels must be as perpendicular to the surface as possible

The housing compartment must not wide enough for the product to fit in.

After having verified the conditions required for a correct installation, proceed with the product assembly:

- fasten the base of the product to the support surface
- make the various connections to the fireplace in compliance with all the applicable regulations.

Any space between the cladding walls and the product can be closed with a compensation frame that must be easily removed if maintenance is to be performed on the insert.

It is mandatory for the product to be fastened to the support surface as it may tip over when being extracted.

Verify that all the connections (hydraulic and electrical) allow the product to be extracted.

INSTALLING AS A NEW SYSTEM

Evaluate the following elements:

The product support surface must have the following characteristics:

- bear the weight of the product and any accessories
- its texture must allow anchors to be set with dowels for safety purposes
- be perfectly level

After having verified the conditions required for a correct installation, proceed with the product assembly:

- fasten the base of the product to the support surface
- make the various connections to the fireplace in compliance with all the applicable regulations.

It is mandatory for the product to be fastened to the support surface as it may tip over when being extracted.

Verify that all the connections allow the product to be extracted.

- Proceed with the cladding assembly.

5-ASSEMBLY

FASTENING TO THE BASE OF THE INSERT

It is mandatory to anchor the product to a support as the authorised technician can remove the combustion chamber from its seat by means of two extendable guides while performing the annual maintenance.

Fasten the insert as follows:

- The depth of the insert inside the frame is 540 mm.
- The safe distance from combustible material is 50 mm
- If the product is to be installed with the pellet loading from the front, simply leave 50 mm behind the product (safe distance for flammable material); if the pellet loading is to be on the side, 50 mm can still be left behind the product, however, tilt the pipes of both the combustion air and the loading. Otherwise, the door cannot be fastened to the wall. If the pipe is kept straight outwards, at least 150 mm must be left behind.

Proceed as follows, irrespective of the loading position selected (front or side):

- Remove the compensation frame C (see the relative paragraph).
- Loosen the lower screws (B) under the frame.
- Then remove the machine and separate it from its support (D).
- Place the support (D) 50 mm (MIN.) away from the wall.

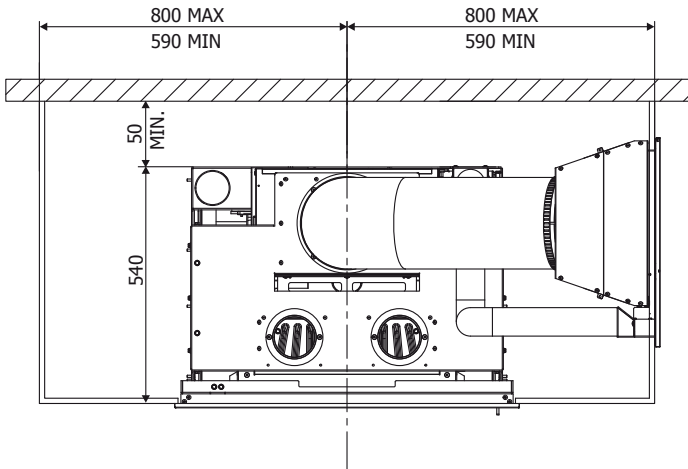

- Fasten the support (D) to the base (E) with the screws supplied, making sure that the support anchor surface (D) and the wall are perpendicular.
- Set the machine back on the support (D), insert the screws (B) again, making sure the machine and the support are well secured in order to guarantee product operation.

It is very important to make sure the positioning measurements of the product base have been respected and the support anchor surface and the wall are perpendicular. Also make sure that the screws secure the machine to the support.

5-ASSEMBLY

The product can be installed at the desired height by constructing a suitable platform. This support must be made of non-flammable material.

The company declines all liability for any damage to objects and persons if the above-mentioned precautions are not complied with.

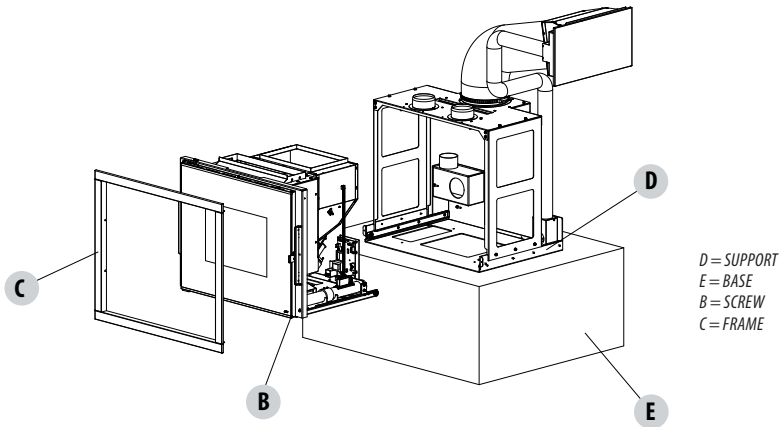

REMOVING THE COMPENSATION FRAME

In order to prevent damaging the finishing frame (C) around the door, it is recommended to remove it before fastening the product to the base (E) and set in a safe place.

FITTING THE PELLET LOADING CHUTE

The side on which the fuel loading chute is to be installed must be decided upon before setting the product in place. The VIVO 80 PELLET is delivered with two clamps, the connection pipe and the chute with a door.

The chute can be fitted on the right, left or at the front. The connection pipe is 1 metre long.



The connection pipe must be shortened according to its position (side or front) for it to be taut and form a slight angle from the horizontal line. This is required for the pellets to go down.

Before applying the cladding, run a fuel loading test to make sure the fuel descends properly to the hopper.

The pipe must be insulated properly if this is fitted on the left side, in correspondence with the smoke expulsion.

The manufacturer declines all liability if the above mentioned warning is not complied with.

Fire hazard!!

5-ASSEMBLY

FITTING THE CHUTE AT THE SIDE

If the chute is to be placed at the side, the distance from the axis of the machine to the wall must not exceed 80 cm (figure at the side). Proceed as follows to set the chute in place:

- Connect the supplied pipe to the Vivo 80 Pellet, making sure it is turned sideways, and fasten it with the clamp.
- Connect the pipe (upper part) to the opening of the door structure with the supplied clamp.
- Position the pipe with the door structure in such a way that, once the cladding is installed, the pipe can be tightened and fixed to the wall of the cladding in line with the hole made for it to be inserted.
- Refer to the relative paragraph to fit the external door, since this is to be carried out once the cladding is completed.

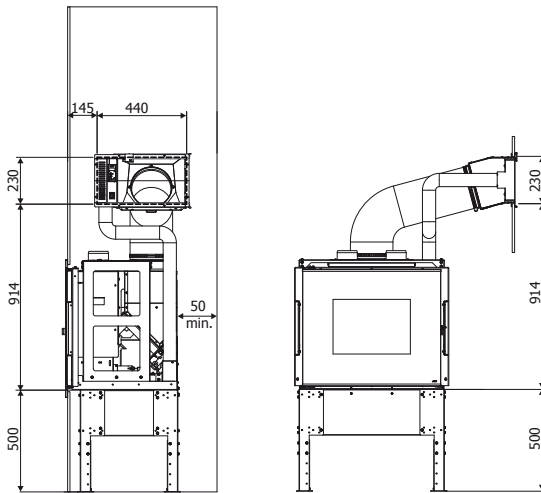

FITTING THE FRONT CHUTE

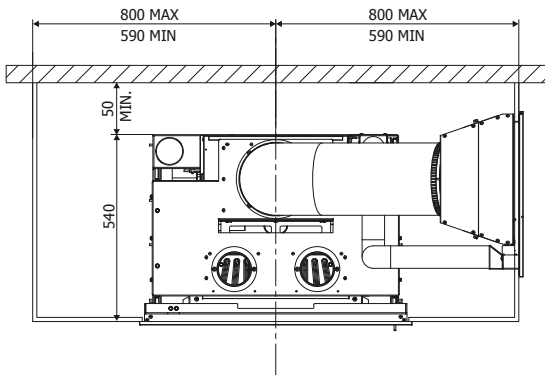

FITTING THE SIDE CHUTE

5-ASSEMBLY

PRODUCT INLET HOLE

The hole made on the wall must be 765*610 mm. These measurements allow the frame to cover the gap that remains between the product and the hole and also allow the product to be removed if maintenance is to be performed and/or parts are to be replaced.

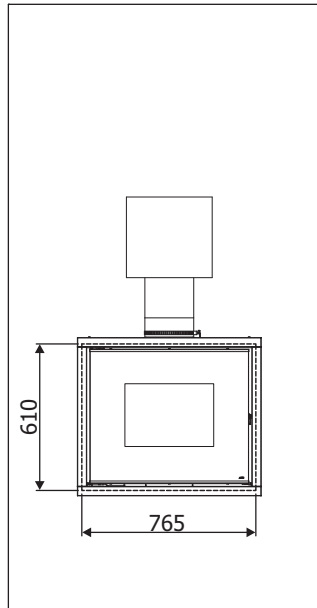

FITTING THE CHUTE AT THE FRONT

Proceed as follows if the pipe is to be positioned at the front:

- Connect the supplied pipe to the product, making sure it is turned to the front, and fasten it with the clamp.
- Connect the pipe to the opening of the door structure with the supplied clamp.
- Position the pipe in such a way that it is accessible once the cladding is completed and for the door structure to be fastened to the preset hole on the wall of the cladding itself.
- Refer to the relative paragraph to fit the external door, since this is to be carried out once the cladding is completed.

CONNECTING THE SWITCH AND CONTROL PANEL

The control panel and switch are already fitted on the pellet loading door and connected to the respective wires by the manufacturer. Connect the wire of the switch to the socket on the rear side of the product.

The wire of the control panel must be connected to the electric board in position 1. T

o fix the switch to the pellet loading hatch one must temporarily disconnect the cables. Reconnect the cables to the relative terminals as shown in the figure.

N = BLACK
R = RED
B = BLUE
M = BROWN

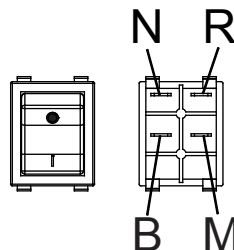

5-ASSEMBLY



Pay utmost attention when handling the panels connected to the relative wires.

The wires must be kept away from heat and where they cannot be damaged if the product is extracted.

Correct operation requires the flat wire and the wire of the switch to be kept away from each other when passing them through, following different routes.

Never force the connector.

Do not bend and/or twist the wires.

Do not modify the connectors, the wires or the supports of the panels.

ASSEMBLING THE DOOR

Once the electrical wiring is complete, run a test operation before fitting the door of the hood.

If the test is successful, fasten the door to the hood with four screws, using the four holes on the frame of the door itself marked with the letter (B).

The holes marked on the horizontal profiles of the door (A) are used to fasten the frame of the door to the frame of the chute, in order to secure the two parts by closing the wall of the hood in the middle.

A rectangular hole must be made on the hood in advance, at a height that is determined by how the optional support has been installed or how the masonry rise has been built.

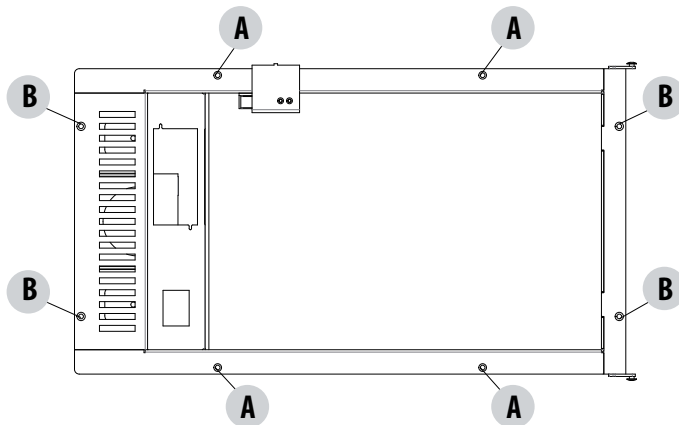

OPENING/CLOSING THE PELLET DOOR

The door closes by means of pressure and therefore has no handles or knobs.

The door is opened by pressing the top left corner. It will lock or unlock with the closing device on the frame of the door when this is pressed.

5-ASSEMBLY

HOOD VENTILATION GRILLES

Foreword

Ventilation grilles must be set up according to how the product is placed.

If inserted in existing cladding, the ventilation grilles on the cladding will be used.

If used as a new installation, the company recommends installing the ventilation grilles as described in the following paragraph.

However, it is important to set-up 2 openings, one on the top part and the other on the lower part of the cladding.

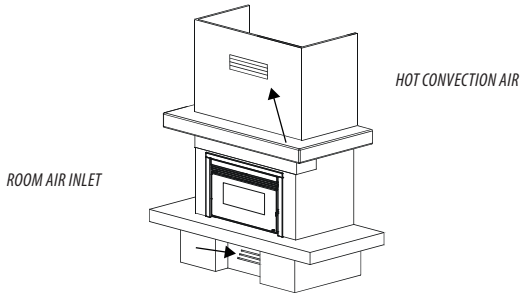

HOOD VENTILATION GRILLES FOR NEW CLADDING

It is mandatory to install the hood ventilation grilles of the manufacturer or grilles that can guarantee the same functions and the same air passage section.

The company cannot be held liable for any damage caused to the structure or the electrical components if this precaution is not complied with.

The structure becomes very hot and constant and efficient ventilation **must** always be guaranteed inside the cladding.

This allows part of the heat of the structure to be recovered that would be lost if left inside the cladding, whilst guaranteeing perfect product operation.

The company supplies 2 "Blade" nozzles; one is to be installed in the upper part and the other in the lower part of the cladding.

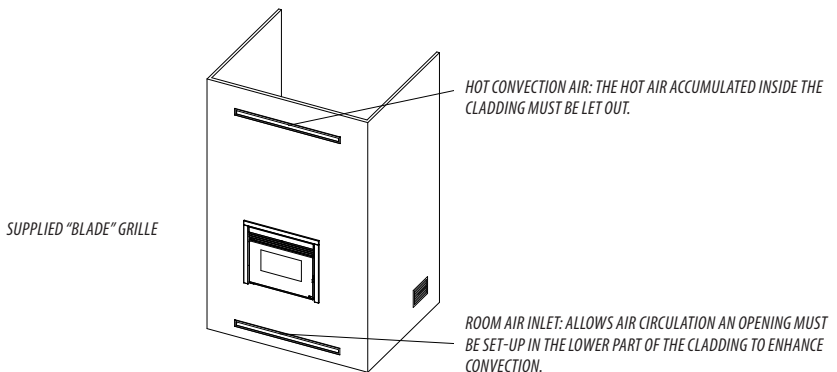

5-ASSEMBLY

ELECTRICAL CONNECTION

First connect the power cable to the rear part of the product and then to a wall socket, which must always be accessible. Should this not be possible, during installation, insert appropriate disconnecting power supply devices, in compliance with the national regulations regarding electrical installations.

It is recommended to disconnect the power cable when the product is not used.

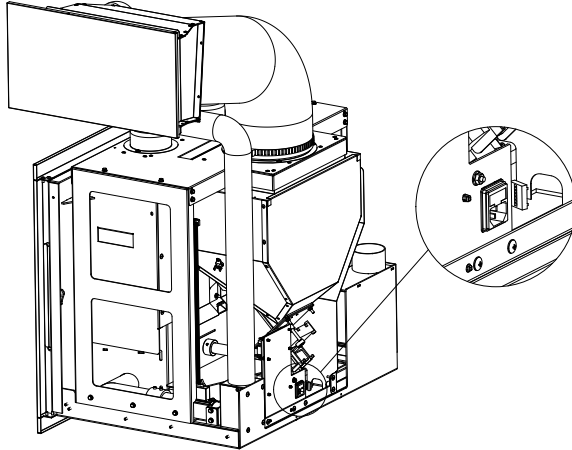

FANS ELECTRICAL CONNECTION

The kit comes with 2.5 metre long silicone cables for fans cabling. Start cabling as follows:

In position 2 connect the yellow/green wire while in position 1 connect the remaining two wires (the colour sequence does not matter as the fans do not have polarization) (fig.7).

The terminal block, to which one must connect the fan cables (fig.8), is screwed to the upper part of the structure.

Connect the two fans earthing cables to the first clamp on the left (T). Connect the remaining two cables from the LH fan with the clamps connected to the white cables (B). Connect the remaining two cables from the RH fan with the clamps connected to the purple cables (V).



IMPORTANT!

The fan connection cable is made of silicone to resist high temperatures. In the event of extension cables (over 2.5 m) and in any case under all circumstances, make sure that the cable does not come into contact with hot parts of the unit, or with air connecting pipes within the cladding or structure.

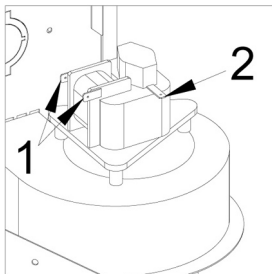

FIGURE 7 – FANS CLAMPS POSITION

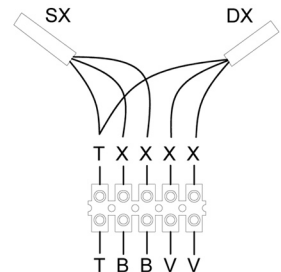
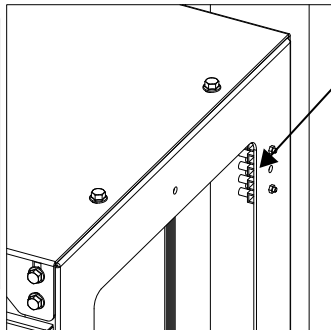

FIGURE 8 – CABLES POSITION ON TERMINAL BLOCK

5-ASSEMBLY

SETTING UP THE CLADDING

The product must be fully tested before the cladding is applied. The company cannot be held liable for any damage to the cladding should operating anomalies arise, which were not verified before the cladding was applied to the product. **IT IS MANDATORY to check the tightness of all the pipes through which smoke passes (smoke fitting, gaskets and flue coupling) before setting up the cladding.**

READ THE "OPERATION TEST" CHAPTER BEFORE SETTING UP THE PRODUCT CLADDING.

The product and the cladding parts must be fastened together **WITH NO CONTACT MADE WITH THE STEEL STRUCTURE** in order to prevent heat from being transmitted to the marble and/or stone and to allow for normal thermal expansion. Pay attention to the wood finishes, such as beams or shelves.

It is recommended to set up the counter hood made of 15 to 20 mm thick fireproof plasterboard with a freestanding frame made of a galvanised profile to prevent bearing the weight on the cladding components (wooden beams or marble lintels), which do not have a freestanding structure **in order to intervene easily in case of anomalies and/or future maintenance**. Dry mount the hearth of the cladding, leaving a **1 cm gap** between the insert and the hearth for insulation.

WOODEN BEAM INSULATION

If you wish to mount a wooden beam, it must be protected with adequate insulation from the hot parts in order to prevent the risk of fire or damage to the cladding.

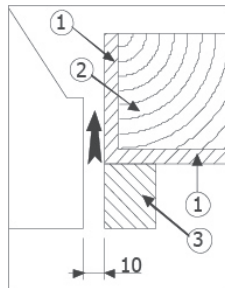

FIGURE 8 - BEAM INSULATION

1. INSULATION: APPLIED OR TO BE APPLIED
2. WOODEN BEAM
3. MARBLE OR OTHER MATERIAL

STANDARD CLADDING ASSEMBLY

The installation guide found in each specific cladding must be referred to for the setting up of MCZ product specific claddings.

5-ASSEMBLY

ASSEMBLING THE COMPENSATION FRAME

Once the cladding and/or the plasterboard is set up, fit the previously removed compensation frame.

This frame intends to finish and cover the gap between the metal structure of the product and the cladding.

The frame is assembled by simply opening the door of the product, fitting in the frame as shown in the figure and fastening it to the lateral columns of the structure, inside the door profile, with the four screws supplied.

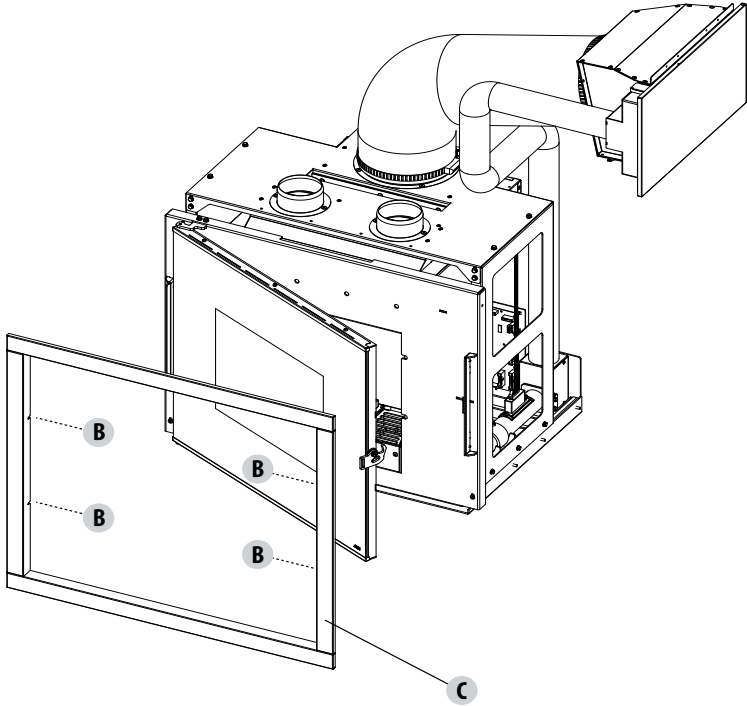

C = FRAME
B = SCREW

6-FIRST START-UP

GENERAL PRECAUTIONS

Remove all components that could burn from the firebox and the glass (instructions, various adhesive labels and any polystyrene).

Check that the brazier is positioned correctly and rests properly on the base.

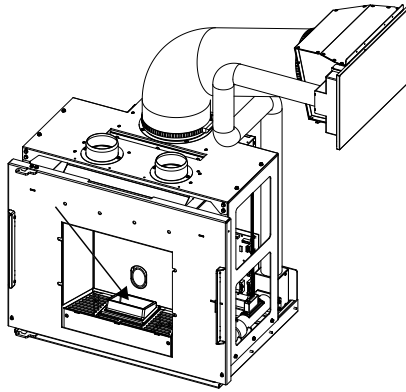

After a long period of inactivity, remove any pellets left in the hopper (**using a vacuum cleaner with a long pipe**), as they could have absorbed moisture, thereby altering their original characteristics and no longer being suitable for combustion.



The first start-up may not be successful as the feed screw is empty and does not always manage to load the required amount of pellets in the brazier in time for the fire to be regularly ignited.

If a flame does not ignite after a number of failed start-ups, even though the pellet supply is correct, make sure the brazier is set in place correctly, which must be **interlocked in its seat and clean from any ash deposits**. If no anomaly is found during this inspection, there may be a problem with the product components or installation may not be correct.



REMOVE THE PELLETS FROM THE BRAZIER AND CONTACT AN AUTHORISED TECHNICIAN.



Avoid touching the product during the initial start-up, as the paint hardens during this phase. If you touch the paint, the steel surface may be exposed.

If necessary, touch up the paint with the spray can of the specific colour.



It is good practice to guarantee effective ventilation in the room during the initial start-up, as the product will emit some smoke and smell of paint.

Do not stand close to the product and air the room. The smoke and smell of paint will disappear after about an hour of operation, however, remember they are not harmful in any case.

The product will be subject to expansion and contraction during the start-up and cooling phases, therefore light creaking noises may be heard.

It is extremely important to make sure the product is not immediately overheated and the temperature is increased gradually starting from the low power. This will prevent damaging the welds and the steel structure.



DO NOT EXPECT HEATING EFFICIENCY IMMEDIATELY!!!

7-LOADING THE PELLETS

LOADING THE PELLETS

Fuel is loaded from the side or front door, which is to be fitted on the cladding, which provides access to the fuel loading chute. The loading procedure is facilitated if performed in a number of steps as described below:

- Open the door and pour half the contents on the chute directly from the bag or using the supplied spade (A)
- Push the pellets accumulated in the chute towards the hopper using the supplied tool (B) and distribute them uniformly.
- Complete the operation by pouring the second half from the bag in the same way



No other type of fuel other than pellets, in compliance with above-mentioned specifications, is to be inserted into the hopper.

Store the spare fuel at an adequate safe distance.

Do not pour pellets directly onto the brazier but only into the hopper.

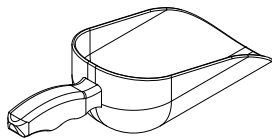

SPADE

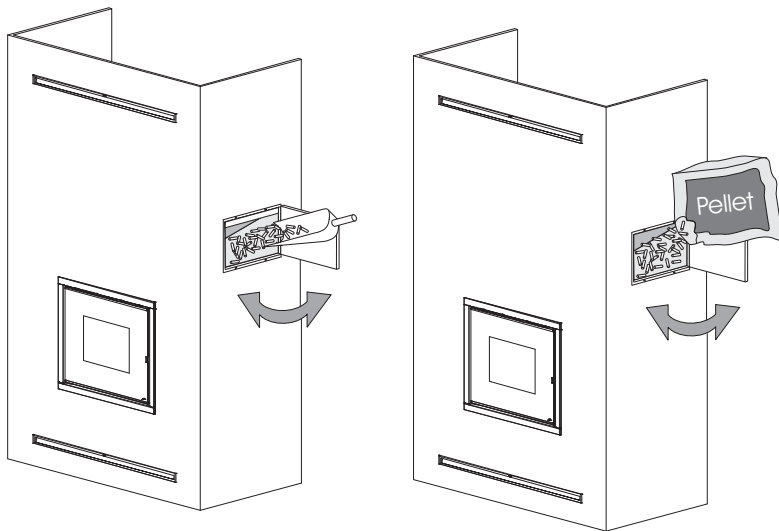

8-LCD REMOTE CONTROL

GENERAL SPECIFICATIONS OF THE LCD REMOTE CONTROL

The remote control works at a transmission frequency of 434.5 MHz.

Power the product with 3 AAA batteries as follows:

- remove the cover of the battery compartment by pressing and lifting the point indicated by the arrow.
- Insert the batteries with the correct polarity (+) and (-).
- Close the cover of the battery compartment.

The time must be set when the remote control is switched on.

The remote control has a special icon on the display to indicate when the batteries are almost flat. If the flat battery icon appears, the batteries are almost flat and the remote control is about to go off.



Used batteries must be disposed of separately in special containers.

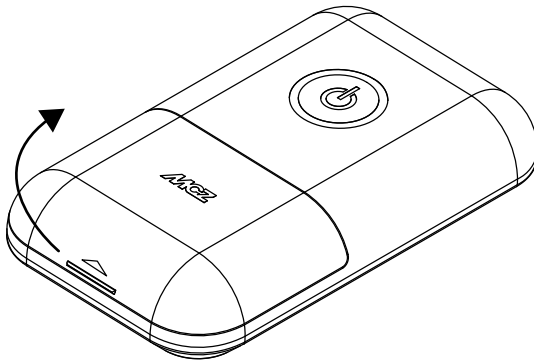

GRAPHIC APPEARANCE

Reference will often be made to the keys. Always keep the figure at hand for simplicity's sake.

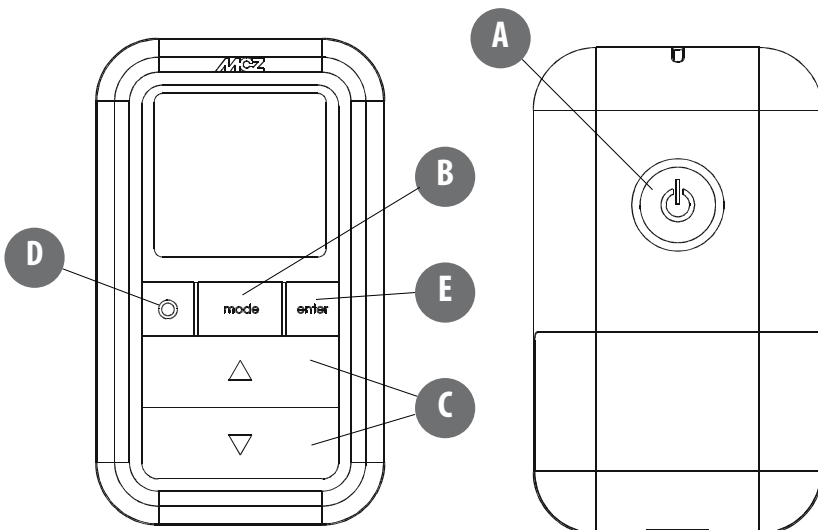

8-LCD REMOTE CONTROL

REMOTE CONTROL OPERATION

GENERAL RULES

Press key **A** for 1" to switch the product on and off. All changes are made with keys **C**. Key **E** is used to confirm the changes. Key **B** is used to select the product operating mode. Key **D** is used to browse the **VENTILATION** and **SLEEP** settings (see "Various settings").

Whichever the mode is, press key **A** briefly (or leave the keypad idle for 7") to go back to the initial display.

INITIAL SETTINGS

SETTING THE TIME

The time/day setting is accessed by pressing keys **B+E** simultaneously for 3", regardless whether the remote control is on or off.

The hour digits will start to flash, which can be modified with keys **C**. Press key **E** to confirm the changes.

The minute digits will then start to flash. Follow the same procedure to modify and confirm the setting and the time display setting (12h or 24h) will then be accessed and lastly, the day will start to flash. Confirm this data to exit the settings.

NOTE: each time the remote control is powered, the time is reset and the display automatically enters the time setting.

°C-°F SETTING

The unit of temperature measurement is changed from Celsius to Fahrenheit and vice versa by pressing key **B** for 5" while the product is off.

SETTING THE OPERATING MODE

One of the following 4 operating modes can be set via key **B** while the remote control is on. The 4 basic displays are shown, respectively, in figures 1-2-3 and 4:

Manual, Automatic, Timer and Eco mode.

MANUAL MODE (MAN)

This mode allows the flame power (changed directly via keys **C**) and ventilation to be set manually in 5 levels + auto (see "Various settings"). Figure 1

AUTOMATIC MODE (AUTO)

This mode allows the desired room temperature to be set and the appliance will automatically adjust the flame power to reach it. The ventilation can be adjusted in 5 levels + auto (see "Various settings"). Figure 2



FIGURE 1
MANUAL MODE.

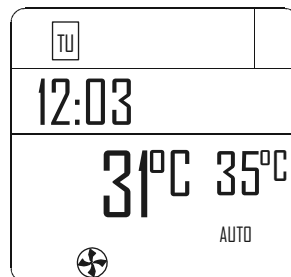

FIGURE 2
AUTOMATIC MODE.

8-LCD REMOTE CONTROL

TIMER MODE (TIMER)

Select this operating mode to switch the product on and off automatically, according to 6 customised time bands (P1 – P6). The following can be set for each time band:

- start-up time.
- Shutdown time.
- Desired room temperature during that time band.
- Days of the week when the time band is to be activated.

When the product is switched on (manually via button A or automatically via a time band), it operates in the automatic mode, described above. A time band appears automatically when it is active (P1 in figure 3) and the desired temperature is changed to the value set in the time band. However, the user can always modify this value as desired and in real time.

Refer to "Timer Settings" to learn how to set the time bands.

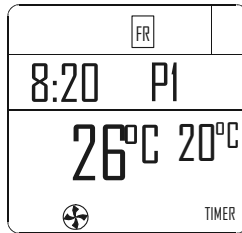

FIGURE 3.

ECO MODE (ECO)

This mode is activated/deactivated by pressing key B for 5" on the remote control while it is switched on.

ECO is an automatic mode with the only difference that if the set temperature is reached and remains so for the subsequent 20 minutes (despite flame modulation), the product is switched off and remains on stand by until the room temperature drops 2 degrees below the desired temperature (and in any case for at least 5 minutes from the last shutdown). The product is then switched on again. Figure 4 If the room is not sufficiently insulated, flame modulation does not allow the set temperature to be met for 20 consecutive minutes and the product will not go off.

NOTE: It is recommended to use the ECO mode only in well-insulated rooms in order to prevent start-up and shutdown from occurring within short periods of time.

The remote control remains on even when the product is off when in ECO mode, in order to indicate that this shutdown is only temporary. Obviously, if the product is switched off from key A, ECO mode is exited and the product remains off.

Up to 6 automatic start-up and shutdown time bands (E1 – E6) can also be set in ECO mode, which are independent from those of TIMER mode (P1 – P6). If they have been activated, TIMER-ECO appears on the display (figure 5) permanently, even if the remote control is switched off.

Refer to "Timer Settings" to learn how to set the time bands.

NOTE: If the remote control is switched off in TIMER mode, ECO mode can only be re-activated by the user (key A) or when started-up by the next valid time band. Combined use of TIMER and ECO modes requires a good knowledge of the product operating logic.



FIGURE 4



FIGURE 5

8-LCD REMOTE CONTROL

VARIOUS SETTINGS

ROOM VENTILATION

The room ventilation can be adjusted as desired in all 4 operating modes described earlier on. Simply follow the steps below: press key D on the initial display to access the **VENTILATION** setting. Then press key C to set the desired ventilation by selecting one of the 5 levels available. The "auto" option can also be selected, which automatically links the room ventilation speed to the flame level.

In brief:

flame set to 1 > ventilation set to 1; flame set to 3 > ventilation set to 3; flame set to 5 > ventilation remains set to 3 (for silent operation as it is in automatic mode).

The speed of each fan (identified with 1 or 2 above the level bars) in products with 2 fans (comfort air models) can be scrolled and set via key D.

NOTE: If the remote control is replaced with a new one and the default settings must be changed, proceed as follows: press keys D + E simultaneously for 10 seconds while the remote control is switched on (until the flashing number disappears). Press key C to select 1 or 2 according to the product to which the remote control is to be paired, and press E to exit.

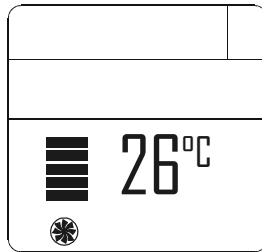

FIGURE 6

SLEEP FUNCTION

The sleep function allows a shutdown time to be set quickly. This function is only available in the **MAN** and **AUTO** modes. It is set as follows: from the **VENTILATION** setting (press key D - see the previous paragraph), press key D again to access the **SLEEP** setting.

The shutdown time is set in 10 minute intervals via key C. Confirm via key D or E and the display returns to the initial page on which the sleep shutdown time remains displayed. Disable the **SLEEP** function by simply accessing the setting and decreasing the time until dashes are displayed and then confirm.

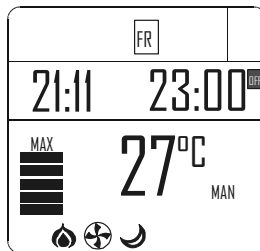

FIGURE 7

8-LCD REMOTE CONTROL

TIMER SETTINGS

DISPLAYING THE TIMER TIME BANDS

Simply press key **D** for 2" to display the time bands in **TIMER** mode. The 6 time bands can be scrolled through with key **C**, thereby verifying all the saved settings. Press key **D** or **A** to return to the initial display.

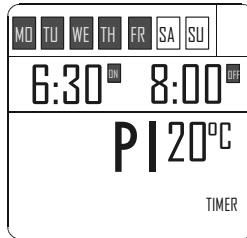

FIGURE 8

MODIFYING THE TIMER TIME BANDS

Modify a time band by displaying it as described in the previous paragraph and then press key **E** briefly.

The first parameter that can be set will start to flash, i.e. the room temperature. Press key **C** to modify the value and key **E** to confirm and move on to the next parameter. The parameters of a time band can be set in the following order:

- room temperature. Can be set between 5° and 35°C. 2 dashes "--" appear if set below 5°C or above 35°C, and if this is confirmed, the program is deactivated (therefore, the product will not be switched on).
- Start-up time. The value is adjusted in 10 minute intervals (from 00:00 to 23:50).
- Shutdown time. The value is adjusted in 10 minute intervals (from 00:10:00 to 24:00).
- Days of the week when the program is to be activated. Monday (MO) will start to flash, followed by the other days of the week. Use key **C** to activate/deactivate the day. The activated days will be displayed on a dark background. When the Sunday (SU) setting is complete, press key **E** to exit the editing page and return to the time bands display.

Press key **D** at any time to save all the changes made (confirmed by pressing key **E**), exit the time band editing page and return to the time bands display.

Press key **A** (or leave the keypad idle for 30") to go directly to the initial display, saving all the changes made and confirmed with key **E**.

ACTIVATING THE TIMER-ECO TIME BANDS

6 customised start-up and shutdown time bands (**E1 – E6**) can be activated in the **ECO** mode: press key **D** for 2" and the **TIMER** activation/deactivation function will appear. If the **ON** option is confirmed, the 6 **TIMER-ECO** time bands are accessed and can be modified as described earlier on for the **TIMER**. If the **OFF** option is confirmed, the **TIMER** is disabled and the product returns to the **ECO** mode with no time bands activated.

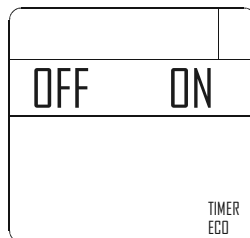
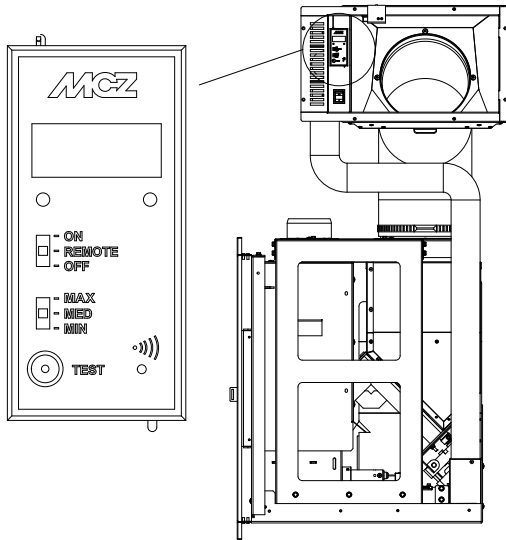

FIGURE 9

9-EMERGENCY PANEL

EMERGENCY PANEL

There is an emergency panel on the product side, designed for any malfunction to be detected and product control if the remote control should malfunction.



KEY

A	Three-digit display that indicates a variety of product information besides the identification code of any malfunction.
B	GREEN LED that indicates: <ul style="list-style-type: none"> • OFF = The product is off • FLASHING ON = The product is starting up • FIXED ON = The product is on
C	RED LED that indicates: <ul style="list-style-type: none"> • OFF = The product is on • ON AND FLASHING SLOWLY = The product is shutting down • ON AND FLASHING QUICKLY = The product is in alarm status (accompanied by a buzzer for the first 10 minutes) • FIXED ON = The product is off
D	3-position selector for the following functions: <ul style="list-style-type: none"> • OFF = The product is switched off manually without the remote control • REMOTE = The product can only be controlled via remote control • ON = The product is switched on manually without the remote control
E	3-position selector for the power selection: <ul style="list-style-type: none"> • MIN = The product runs at MINIMUM power without the remote control and with selector 4 set to ON • MED = The product runs at MEDIUM power without the remote control and with selector 4 set to ON • MAX = The product runs at MAXIMUM power without the remote control and with selector 4 set to ON
F	Button for diagnostic functions regarding the product operation mode
G	Button to connect the product to a new remote control



SELECTOR "D" MUST BE SET TO THE "REMOTE" POSITION FOR THE PRODUCT TO BE REMOTE CONTROLLED.

9-EMERGENCY PANEL

EMERGENCY PANEL START-UP/SHUTDOWN

If the remote control is faulty or the batteries are flat, the product can be operated in safe mode via the rear emergency panel. In this configuration, the product can only work in manual mode and one of 3 power levels can be selected.

- **APPLIANCE START-UP WITHOUT THE REMOTE CONTROL.**

Switch the product on by bringing selector "D" to the **ON** position. The RED LED goes off upon start-up, whereas the GREEN LED starts to flash until the start-up phase is complete. Once the product runs smoothly, the GREEN LED remains on.

- **SELECTING THE POWER WITHOUT THE REMOTE CONTROL.**

One of three heating powers **MIN-MED-MAX** can be selected (selector "E"):

The **MINIMUM** power corresponds to the 1st power.

The **MEDIUM** power corresponds to the 3rd power.

The **MAXIMUM** power corresponds to the 5th power.

- **APPLIANCE SHUTDOWN WITHOUT THE REMOTE CONTROL.**

Switch the product off by bringing selector "D" to the **OFF** position.



Once the remote control is restored, remember to set selector "D" back to the "REMOTE" position, otherwise the product will ignore the remote control commands.

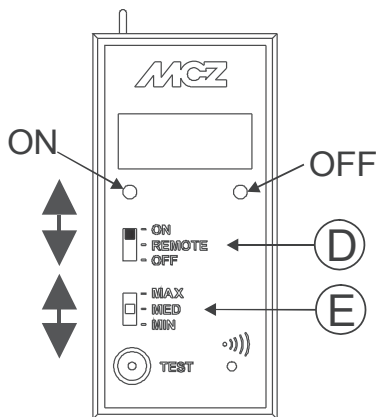

SWITCH-ON/OFF FROM THE EMERGENCY PANEL

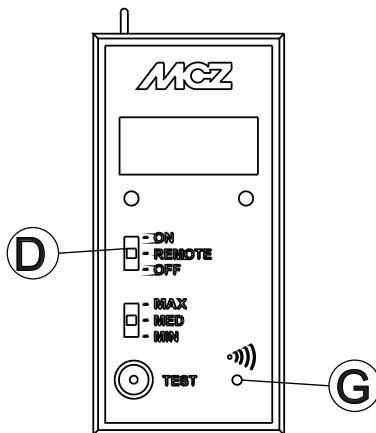

REMOTE CONTROL SYNCHRONIZATION

SYNCHRONIZATION OF REMOTE CONTROL

Upon first start-up of the product, it may be necessary to get the stove to recognize the new remote control. To carry-out this operation, follow the simple instructions that follow:

- connect the stove to the socket and switch the power supply button on
- ensure that the selector D of the emergency panel is in the position REMOTE
- when the first text appears onto the display of the emergency panel, press the embedded button G with the aid of a pointy object (toothpick..)
- three flashing lines "----" will appear on the display. Press the on/off button of the remote control for confirmation.

The three flashing lines will disappear from the display and the stove will recognise the new communication address of the remote control. Recognition will also be confirmed by 4 acoustic sounds.

9-EMERGENCY PANEL

FEED SCREW LOADING

This function can only be activated when the product is off and allows the pellets to be loaded into the feed screw (loading system). It can be used each time the pellets finish in the feed screw and hopper (see alarm A02). It is useful to prevent failed start-ups (alarm A01) due to the hopper being empty.

The FEED SCREW LOADING function is activated as follows (with the product off): bring selector "D" on the emergency panel to OFF and press the **TEST** key on the same panel three consecutive times. Wait a few seconds and FEED SCREW will flash on the display.

Press the TEST key once again when the pellets begin to fall into the brazier to end the LOAD FEED SCREW function and proceed with the product start-up.

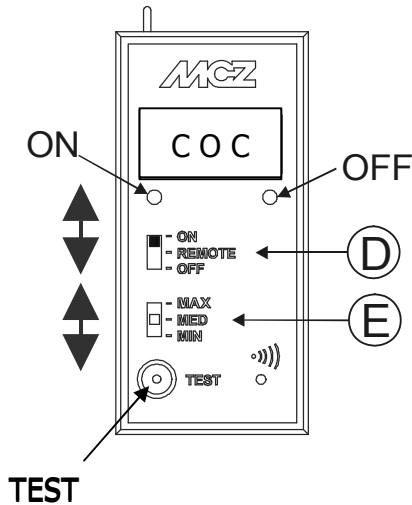

10-SAFETY DEVICES AND ALARMS

SAFETY DEVICES

The product is supplied with the following safety devices:

SMOKE TEMPERATURE PROBE

Detects the temperature of the smoke, thereby enabling start-up or stopping the product when the temperature drops below the preset value.

PELLET HOPPER SAFETY THERMOSTAT

If the temperature exceeds the preset safety value, it immediately stops the product, which must cool down before being restarted. Selector "D" must be set to "Off" for the product to be restored.

ELECTRICAL SAFETY

The product is protected against sudden changes in current by a main fuse in the power supply panel on the rear part of the product. Other fuses that protect the electronic boards are found on the latter.

SMOKE FAN FAULT

If the fan stops, the electronic board promptly blocks the supply of pellets and the alarm is displayed.

GEAR MOTOR FAULT

If the gear motor stops, the product continues to work until the minimum cool level is reached.

TEMPORARY POWER CUT

If a power cut occurs during operation, the product automatically sets itself in cooling mode when the power is restored and then restarts.

FAILED START-UP

If no flame is developed during start-up, the product will go into alarm status.



IT IS FORBIDDEN TO TAMPER WITH THE SAFETY DEVICES.



The product can be started-up and the automatic function of the probe restored only after having eliminated the cause that triggered the safety system. This manual will help you understand which anomaly has occurred, and explain how to intervene according to the alarm message displayed on the product.

10-SAFETY DEVICES AND ALARMS

ALARM ALERTS

If an operating anomaly occurs, the product enters the shutdown phase due to an alarm and informs the user regarding the type of fault by means of a 3 digit code that remains displayed on the emergency panel.

The alarm is indicated permanently by the relative 3 digit code, a flashing red LED that lights up on the emergency panel and an intermittent buzzer for the first 10 minutes. Read the instructions in the following 2 paragraphs to cancel the alarm status and restore the normal operating mode of the stove. The following table describes the possible alarms indicated by the product, associated to the respective code that appears on the emergency panel and helpful tips to resolve the problem.

DISPLAY MESSAGE	TYPE OF PROBLEM	SOLUTION
A01	The flame does not light	Check the level of pellets in the tank. Check that the brazier is correctly positioned in its seat and has no incrustation or unburned material. Make sure the ignition plug warms up. Thoroughly empty and clean the brazier before restarting.
A02	The fire goes off abnormally.	Due to the hopper being empty (no fuel).
A03	The pellet hopper temperature exceeds the intended safety threshold. The structure overheats due to reduced heat dissipation.	The structure is too hot because the product has been used for too long at the maximum power or due to poor ventilation or because the air fans are faulty. When the product is sufficiently cold, press button B on the control panel or OFF on the remote control to delete alarm A03. Once the alarm is deleted, the appliance can be switched on.
A04	The temperature of the exhaust smoke has exceeded the preset safety limits.	The appliance switches off automatically. Let the product cool down for a few minutes and then switch it on again. Check the smoke expulsion and the type of pellets used.
A05	Clogged flue-wind-door open.	Check the smoke duct and make sure the door is closed.
A06	The smoke extractor fails to guarantee sufficient primary air, required for a correct combustion.	Insufficient draught or clogged brazier. Verify whether the brazier is clogged and clean it, if necessary. Check and if necessary clean the smoke duct and air inlet.
A08	Faulty smoke fan.	Verify whether the smoke fan compartment is clean, and particularly if it is blocked by dirt. If this does not suffice, the smoke fan is faulty. Contact an authorised service centre to have it replaced.
A09	The smoke probe is faulty and does not detect the exhaust smoke temperature correctly.	Contact an authorised service centre to have the component replaced.

10-SAFETY DEVICES AND ALARMS

A10	The spark plug is faulty.	Contact an authorised service centre to have the component replaced.
A11	Pellet supply fault.	Contact an authorised service centre to have the component replaced.
A12	The remote control has been out of the product reception range for over 3 hours (or the batteries are flat). NOTE: the appliance does not enter the shutdown phase due to an alarm only in such a case, and continues to work in the mode set by the remote control via the last command.	Move the remote control within the product reception range (or change the batteries of the remote control if they are flat). The alarm alerts will disappear as soon as the appliance receives a new signal from the remote control. A simple way of forcing signal transmission to the product is by pressing button 4 (which changes the operating mode from manual to automatic and vice versa).
A13	General fault in the electronic control unit.	Contact an authorised service centre to have the component replaced.
A14	Faulty air flow rate sensor.	This alarm does not block the system and only a warning screen is displayed. Contact an authorised service centre to have the component replaced.
SEr	Routine maintenance alert.	This flashing message upon start-up indicates that the preset operating hours before maintenance is due have elapsed and a qualified technician, recommended by the manufacturer, must be contacted for maintenance to be performed.

DELETING THE ALARM STATUS

Follow the procedure described below to restore normal product operation after an alarm has been triggered:

- set selector D on the rear emergency panel to OFF for a few seconds until the 3 digit alarm identification code disappears. The red LED stops flashing and the alarm buzzer is silenced by performing the steps below.
- Set selector D back to the REMOTE position for product operation to be remote controlled.
- Switch the remote control off and then on again if the product is to be switched on.



Only if alarm A12 is triggered (no communication between the remote control and the product), the appliance remains on according to the last mode set and automatically exits the alarm mode when the first signal is received from the remote control.

10-SAFETY DEVICES AND ALARMS

BLOCKED PRODUCT

The following may cause the product to be mechanically blocked:

- the structure overheats (“**A03**”).
- The smoke is overheated (“**A04**”).
- During product operation, air that has not been controlled in the combustion chamber has entered or the chimney is clogged (“**A05**”).

SOLUTIONS:

if “**A03**” appears, the structure is too hot because the product has been used for too long at the maximum power or due to poor ventilation or because the air fans are faulty.

When the product is sufficiently cold, press button B on the control panel to delete alarm A03. Once the alarm is deleted, the product can be switched on.

If “**A04**” appears, the product will shutdown automatically, let it cool down for a few minutes and then switch it on again. Delete the alarm and switch the product on again.

If “**A05**” appears, the door has been left open for too long or a significant amount of air has entered (e.g. missing smoke fan inspection cap). If these causes are excluded, check and if necessary clean the smoke duct and chimney.

Only after having eliminated the cause permanently can the product be switched on again.

11-RECOMMENDATIONS FOR SAFE USE



ONLY CORRECT INSTALLATION AND APPROPRIATE MAINTENANCE AND CLEANING OF THE APPLIANCE CAN GUARANTEE CORRECT OPERATION AND SAFE USE OF THE PRODUCT.

We would like to inform you that we are aware of cases of malfunctioning of domestic pellet-fuelled heating products, mainly due to incorrect installation and inappropriate maintenance.

We would like to assure you that all of our products are extremely safe and certified according to European standards of reference. The ignition system has been tested with the utmost attention to enhance ignition efficiency and to prevent any type of problem, even in the worst operating conditions. In any case, like for any other pellet-fuelled product, our appliances must be installed correctly and undergo regular periodical cleaning and maintenance to guarantee safe operation. Our studies show us that malfunctioning is mainly due to the combination of part or all of the following factors:

- Brazier holes obstructed or brazier deformed, due to lack of maintenance and conditions which can cause delayed ignitions, generating an anomalous production of unburned gases.
- Insufficient combustion air due to a reduced or clogged air inlet duct.
- Use of smoke ducts nonconforming to regulatory installation requirements, failing to guarantee an adequate draught.
- Partially clogged chimney, due to lack of maintenance, reducing the draught and making ignition difficult.
- End chimneypot nonconforming to the indications of the instruction manual, and therefore not suitable to prevent potential inverse draught.
- This factor is crucial when the product is installed in especially windy areas, such as coastal regions.

The combination of one or more of these factors could generate important malfunctioning conditions.

To keep this from occurring, it is fundamental to guarantee that the product is installed in compliance with standards in force.

Furthermore it is of the utmost importance to respect the following simple rules:

- Every time the brazier is removed for cleaning, it must always be put back properly in the work position before using the product, completely removing any residual filth left on the support base.
- Pellets must never be loaded in the brazier manually, either before ignition or during operation.
- The accumulation of unburned pellets ensuing a failed ignition must be removed before repeating ignition. Also check that they are fed correctly and that the combustion air inlet/smoke outlet are regular.
- If ignition fails repeatedly, immediately suspend use of the product and contact a qualified technician to check its operation.

Compliance with these indications is absolutely sufficient to guarantee proper operation and to avoid any type of problems with the product.

If the above-mentioned precautions are not taken, and during ignition the brazier is overloaded with pellets thus generating anomalous smoke in the combustion chamber, carefully follow the indications below:

- Do not disconnect electrical power to the product for any reason whatsoever: this would stop the smoke extractor, releasing smoke into the environment.
- Take the precaution of opening the windows to ventilate the installation room from any smoke in the environment (the chimney might not work properly).
- Do not open the fire door: this would compromise regular operation of the smoke extraction system to the chimney.
- Just switch the stove off by acting on the on-off button on the control panel (not the rear power supply socket button!) and move away until smoke has completely evacuated.
- Before attempting re-ignition, clean the brazier and its air passage holes completely of all deposits and unburned pellets. Put the brazier back in place, removing any residue from its support base. If ignition fails repeatedly, immediately suspend use of the product and contact a qualified technician to check its operation and the chimney.

12-MAINTENANCE AND CLEANING

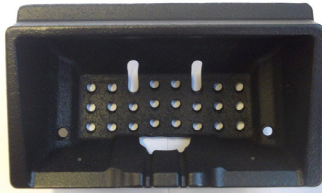

EXAMPLE OF A CLEAN BRAZIER



EXAMPLE OF A DIRTY BRAZIER

Only by properly servicing and cleaning the product is it possible to ensure its safety and correct operation.



ATTENTION!

All the cleaning operations of all parts must be performed with the product completely cold and the plug disconnected.

Disconnect the product from the 230V power supply before performing any maintenance operation.

The product requires little maintenance if used with certified good quality pellets.

DAILY OR WEEKLY CLEANING PERFORMED BY THE USER

Brazier cleaning

Before ignition, always clean the brazier and remove any ash or incrustation from it that might obstruct the air flow holes, paying attention to hot ash. In the case of ignition failure, or if fuel in the tank runs out, unburned pellets may accumulate in the brazier. Always empty the residue in the brazier before each start-up. **You may only use a vacuum cleaner to remove ash when it is completely cold.** In this case, use a suitable vacuum cleaner to remove small sized particles.



REMEMBER THAT ONLY A CORRECTLY POSITIONED AND CLEAN BRAZIER CAN GUARANTEE IGNITION AND OPTIMAL OPERATION OF YOUR PELLET PRODUCT. IN CASE OF FAILED IGNITION AND AFTER ANY OTHER LOCK STATE OF THE PRODUCT, IT IS ESSENTIAL TO EMPTY THE BRAZIER BEFORE EVERY RESTART

For the brazier to be cleaned properly, remove it from its housing completely and thoroughly clean all the holes and the grate on the bottom. If good quality pellets are used, you will normally only need to use a brush to restore the optimal operating conditions of the component.

Ash tray cleaning

Remove and empty the ash tray. Wipe away any residual ash before reinserting the tray. Your experience and the quality of the pellets will determine the ash tray cleaning frequency. **However, it is recommended not to exceed 2 or 3 days.**

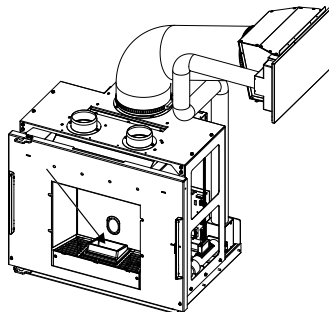

CLEANING THE ASH COLLECTION COMPARTMENT

12-MAINTENANCE AND CLEANING

CLEANING THE GLASS

It is recommended to clean the ceramic glass with a dry brush, or if it is very dirty, spray a little specific detergent and clean with a cloth.



ATTENTION!

Do not use abrasive products and do not spray the glass spray cleaner on the painted parts or the door gaskets (ceramic fibre cord).

PERIODIC CLEANING PERFORMED BY A QUALIFIED TECHNICIAN

PULLING THE PRODUCT OUT

Part of the product must be extracted from its seat for maintenance to be performed on certain devices and to clean certain parts. The mobile part is fitted on sliding guides, which facilitate the handling process. The compensation frame must be removed by following the instructions in this manual before pulling the product out in order to prevent any damage during maintenance. The two lower front screws must be removed from the product in order to pull it out.

Once the screws are removed, simply exert slight force towards you to pull the mobile part like a drawer. The guides have an end-of-travel that block the mobile part when extracted completely.



ATTENTION: THE PRODUCT MUST ONLY BE PULLED OUT WHEN COLD AND THE POWER SUPPLY MUST BE DISCONNECTED IN ADVANCE.

When the mobile part is set back in place, make sure the two screws removed previously are tightened well. The product may not work if the above is not done, due to no power supply or leaking soot.

CLEANING THE HEAT EXCHANGER

The compartment through which the exhaust smoke passes must be cleaned at the end of the winter season.

This cleaning process is mandatory in order to facilitate the general removal of all combustion residue, before it becomes very difficult to remove it due to the humidity compacting it over time.

If necessary, clean it more often.



It is good practice to guarantee effective ventilation in the room while cleaning the product.

When the appliance is cold, open the door and remove the ash pan as well as the brazier. Then loosen the three screws just above the hearth opening and remove the bracket that blocks the internal refractory parts made of Alutec.

Gently remove the lateral sides and then the rear panel with the bracket that keeps it blocked in place.

12-MAINTENANCE AND CLEANING

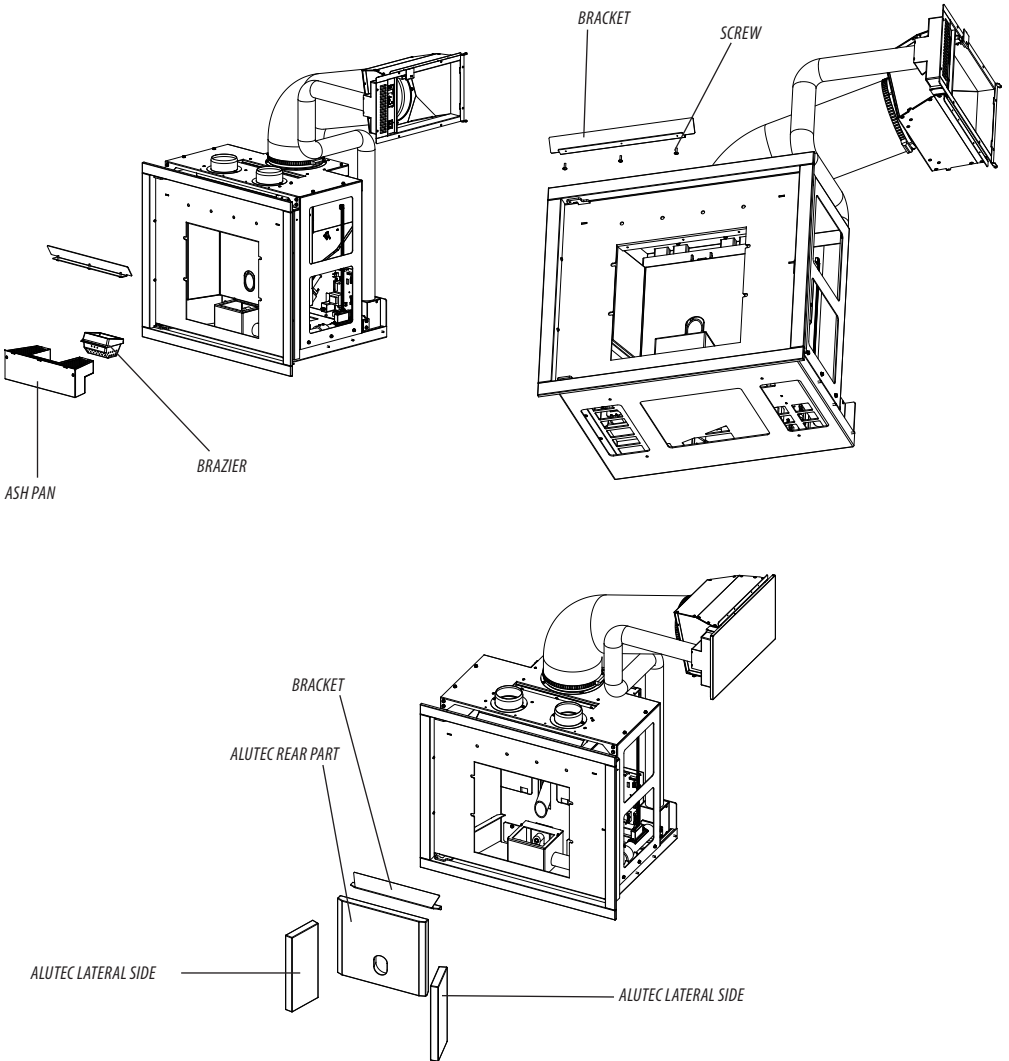

Be careful not to knock the refractory parts when removing them as they could chip or break. Set them in a safe place until they are to be fitted again.

12-MAINTENANCE AND CLEANING

Then remove the upper plate "Q". Remove it from its seat by lifting it and then tilting it slightly downwards.

Scrape the walls of the firebox with a rigid rod or a bottle brush into plate "Q" that has just been removed, for the ash to fall into the lower part where the inspection holes are located (under plates "R").

Loosen the bolts and remove the inspection plates "R" beneath the ash pan, and use the brush and nozzle of the vacuum cleaner to remove the ash and soot accumulated in the heat exchanger.

Then reassemble all the parts by following the above-mentioned steps in reverse order.

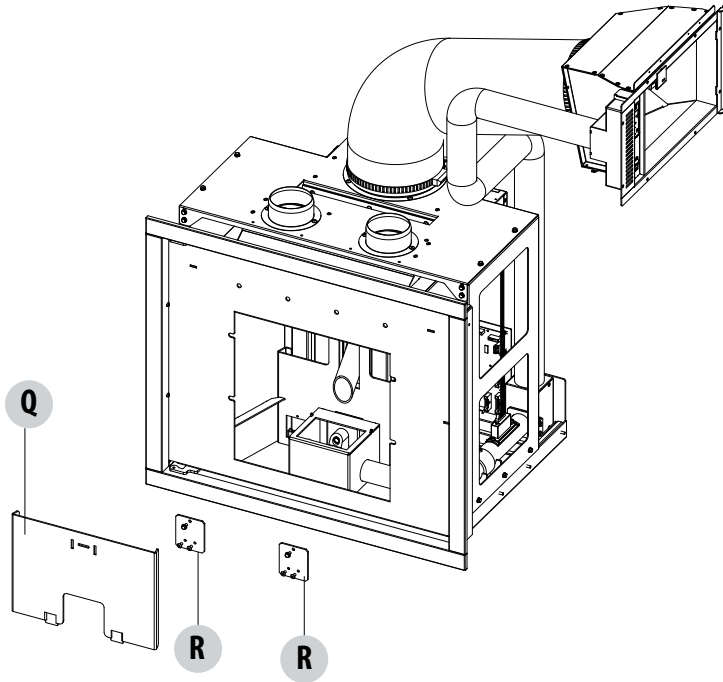

Q = UPPER PLATE
R = INSPECTION PLATE

12-MAINTENANCE AND CLEANING

CLEANING THE SMOKE DUCT AND FITTING

When the product is extracted, you can intervene on the smoke fan (1) from the left side for cleaning and maintenance purposes. Clearly, the smoke evacuation fan must be removed for such maintenance to be performed.

A gasket (3) is applied on the fan outlet, which guarantees the tightness with the smoke fitting (2). Always verify that this gasket is intact and if necessary, replace it. The gasket can also be adjusted via a screw. The pressure on the fitting can be increased or decreased by loosening the screw.

The flue connection to its ash collection compartment (4) is located in the rear/lateral part of the product, in line with the fan outlet. Also clean this compartment with a vacuum cleaner by inserting the nozzle on the fan inlet hole.

Then clean the smoke exhaust, especially around the fittings, curves and any horizontal sections. For information on cleaning the flue, contact a chimney sweeper.

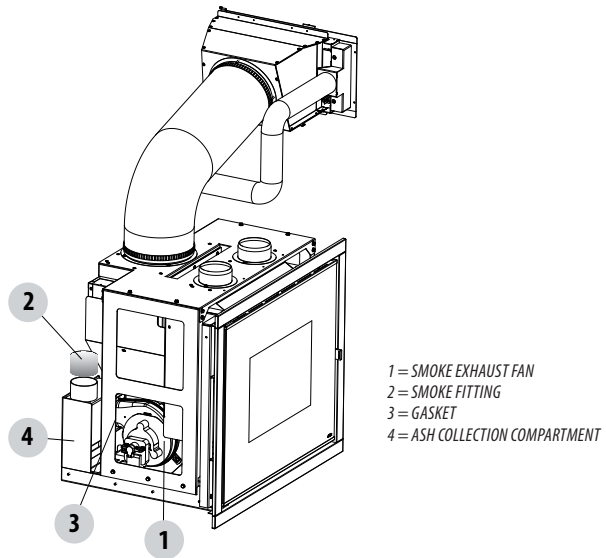

ATTENTION! *The frequency with which the smoke exhaust must be cleaned depends on the use of the product and the type of installation.*

OTHER CHECKS

All the tightness gaskets fitted on the components on which maintenance is to be performed (smoke evacuation fan, inspection sections, etc.) must be replaced when these are removed for maintenance purposes. Verify the tightness of the gaskets on the hearth door and if necessary, contact an authorized service centre for them to be replaced.

The company recommends contacting an authorised service centre for end-of-season maintenance and cleaning as the above-mentioned operations will be performed together with a general inspection of the components.

12-MAINTENANCE AND CLEANING

END-OF-SEASON SHUTDOWN

At the end of each season, before switching the product off, it is recommended to remove all the pellets from the hopper with a vacuum cleaner that has a long pipe.

The product must be disconnected from the mains when it is not used.

CHECKING THE INTERNAL COMPONENTS



ATTENTION!

The internal electromechanical components must only be checked by qualified personnel whose technical expertise includes combustion and electricity.

It is recommended to perform this routine maintenance annually (with a scheduled service contract), which focuses on a visual and functional verification of the internal components. The following is a summary of the necessary checks and/or maintenance for the product to work correctly.

PARTS/INTERVAL	1 DAY	2-3 DAYS	30 DAYS	1 YEAR
Brazier	•			
Ash collection compartment	•			
Ash pan	•			
Glass		•		
Complete exchanger				•
Smoke duct			•	
Door gasket				•
Remote control battery (if purchased/optional)				•

13-PROBLEMS/CAUSES/SOLUTIONS



ATTENTION!

All repairs must only be carried out by a specialised technician, with the product switched off and the plug disconnected.

If the product is NOT used as described in this manual, the manufacturer declines all liability for any damage caused to persons and property.

All the necessary measures and/or precautions must be adopted when performing maintenance, cleaning and repairs.

- Do not tamper with the safety devices.
- Do not remove the safety devices.
- Connect the product to an efficient smoke expulsion system.
- Verify that the room in which the appliance will be installed is adequately ventilated.

ANOMALY	POSSIBLE CAUSES	SOLUTIONS
The pellets are not fed into the combustion chamber.	The pellet hopper is empty.	Fill the hopper with pellets.
	Sawdust has blocked the feed screw.	Empty the hopper and remove the sawdust from the feed screw by hand.
	Faulty gear motor.	<i>Replace the gear motor.</i>
	Faulty electronic board.	<i>Replace the circuit board.</i>
The fire goes out or the appliance stops automatically.	The pellet hopper is empty.	Fill the hopper with pellets.
	The pellets are not fed.	See the previous anomaly.
	The pellet temperature safety probe has been triggered.	Let the product cool down, restore the thermostat until the problem is resolved and switch the product back on. If the problem persists contact Technical Assistance.
	The door is not closed properly or the gaskets are worn.	<i>Close the door and replace the gaskets with original ones.</i>
	Unsuitable pellets.	Change the type of pellets with those recommended by the manufacturer.
	Low pellet supply.	<i>Have the fuel flow rate checked by Technical Assistance.</i>
	The combustion chamber is dirty.	Clean the combustion chamber in accordance with the installation guide.
	Clogged outlet.	Clean the smoke duct.
	Faulty smoke extraction motor.	<i>Check the motor and replace it, if necessary.</i>
Triggered clogged flue alarm.	<i>Verify whether the smoke duct is clogged.</i>	

13-PROBLEMS/CAUSES/SOLUTIONS

ANOMALY	POSSIBLE CAUSES	SOLUTIONS
The product works for a few minutes and then switches off.	Start-up phase is not completed.	Repeat start-up.
	Temporary power cut.	Wait for the automatic restart.
	Clogged smoke duct.	Clean the smoke duct.
	Faulty or malfunctioning temperature probes.	<i>Check and replace the probes.</i>
	Faulty spark plug.	<i>Check the spark plug and replace it, if necessary.</i>
Pellets accumulate in the brazier, the glass of the door gets dirty and the flame is weak.	Insufficient combustion air.	Make sure there is an air inlet in the room and it is not clogged. Check that the combustion air filter on the Ø 5 cm air inlet pipe is not clogged. Clean the brazier and check that all the holes are clear. Perform a general cleaning of the combustion chamber and the smoke duct. Check the state of the door gaskets.
	Damp or unsuitable pellets.	Change the type of pellets.
	Faulty smoke evacuation motor.	<i>Check the motor and replace it, if necessary.</i>
The smoke evacuation motor does not work.	The product is not powered.	Check the mains current and the protection fuse.
	The motor is faulty.	<i>Check the motor and capacitor and replace them, if necessary.</i>
	The electronic board is faulty.	<i>Replace the electronic board.</i>
	The control panel is faulty.	<i>Replace the control panel.</i>
The convection air fan never stops.	Faulty or malfunctioning temperature control probe.	<i>Check the probe and replace it, if necessary.</i>
	Faulty fan.	<i>Check the fan and replace it, if necessary.</i>
The remote control does not work.	The remote control battery is flat.	Replace the batteries.
	Faulty remote control.	Replace the remote control.

13-PROBLEMS/CAUSES/SOLUTIONS

ANOMALY	POSSIBLE CAUSES	SOLUTIONS
The product always runs at maximum power when in automatic mode.	The room thermostat is in the maximum position.	Set the thermostat temperature again.
	Faulty temperature probe.	<i>Check the probe and replace it, if necessary.</i>
	Faulty or malfunctioning control panel.	<i>Check the panel and replace it, if necessary.</i>
	Thermostat is set to minimum.	Set the thermostat temperature again.
The product does not go on.	No power supply.	Check that the plug is inserted and the main switch is in the "I" position.
	Faulty pellet probe.	Wait for the water or pellet tank to cool down and restart the product.
	Blown fuse.	Replace the fuse.
	Clogged smoke exhaust or smoke duct.	Clean the smoke exhaust and/or the smoke duct.
	An alarm has been triggered.	Verify the type of alarm and proceed accordingly.
	Check whether the brazier is clean.	Clean the brazier from any deposits or residue of unburned pellets.
	Check the position of the brazier.	Set the brazier back on its seat.
	Check whether the spark plug warms up.	<i>Check and if necessary, replace.</i>

14-WIRING DIAGRAMS

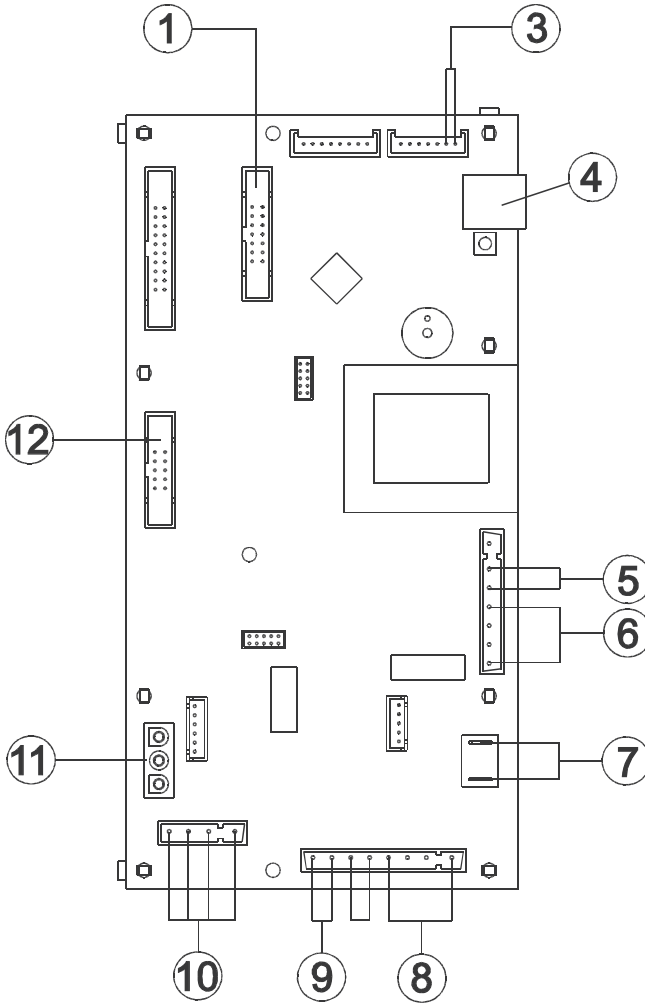

MOTHERBOARD WIRING KEY

- | | |
|------------------------|-------------------------------------|
| 1. CONTROL PANEL | 8. GEAR MOTOR |
| 3. SMOKE PROBE | 9. CONTACT THERMOSTAT |
| 4. MODEM CONNECTION | 10. AIR FAN |
| 5. SWITCH | 11. SMOKE EXPULSION FAN REV CONTROL |
| 6. SPARK PLUG | 12. AIR DOOR PROBE |
| 7. SMOKE EXPULSION FAN | |

N.B. The wiring of the individual components is fitted with pre-wired connectors of different sizes.



MCZ GROUP S.p.A.

Via La Croce n°8
33074 Vigonovo di Fontanafredda (PN) – ITALY

Telefono: 0434/599599 r.a.

Fax: 0434/599598

Internet: www.mcz.it

e-mail: mcz@mcz.it